

Micaflex PFT ver 3. Pressure- and Flow transmitter with control output

MF-PFT ver 3.x

NOTE !

Read through the entire manual before you begin installation and programming.

APPLICATION

MF-PFT is a microprocessor controlled transmitter/controller for measurement and control of differential pressure or flow. With the four keys on the front panel it is possible to access all functions, make settings and scaling the output signal. The double row, 2x16 character, LCD with backlight displays functions and values.

MOUNTING

MF-PFT is designed for wall mounting but can be fitted with an optional frame kit, MFM-PANEL, for recessed mounting on wall or through a cabinet door. MF-PFT is screwed to the wall using four screws, max \varnothing 4mm. Location of screw holes are shown on the backside of the enclosure.

Unscrew the lid and use the bottom screws to temporarily fix the lid on the upper edge of the enclosure during installation. See figure.

OUTPUT SIGNAL

MF-PFT has two analogue output signals which can be used for pressure, flow and control signal. Each output has three terminals, one for Volt DC, one for mA DC and one common zero. The outputs permit using both mA and Volt signal simultaneously.

ALARM

MF-PFT has two alarms, each independent of the other. The alarm is acoustic with beeper and visual with LED indication for pressure or flow, high or low alarm level and manual or automatic reset.

START MENU

When the transmitter is connected to supply voltage, a start menu is displayed.

Using the arrow-keys it is possible to scroll through the different available start menus. To have the unit always displaying the same start menu, it can be selected and programmed in parameter group **System settings**. By pressing the **ESC**-key when other menus are displayed the selected start menu is displayed

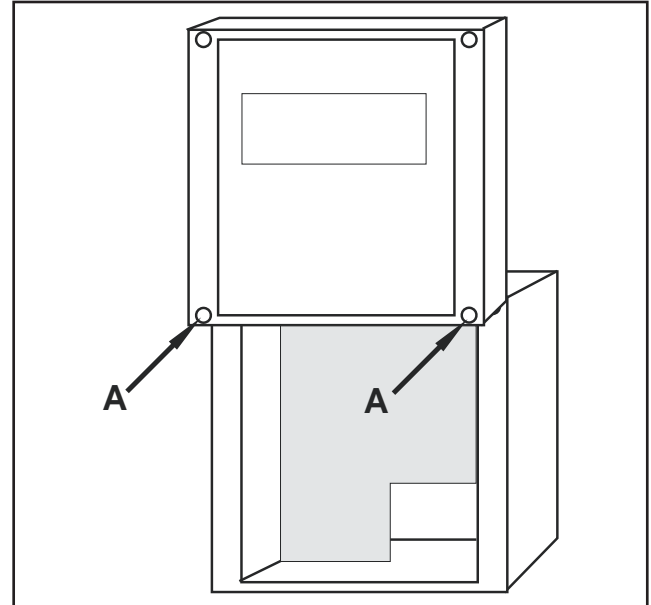

PROGRAMMING

Push the **PGM**-key until "PROGRAM-MENU" is displayed. Release the **PGM**-key and the first parameter group is displayed according to the parameter list on page 2.

Using the arrow-keys it is possible to scroll through the different available parameter groups. **Note**, If code lock is activated, see page 6, the programmed 4-digit access code must be entered to access the menu.

1. Internals
2. System settings
3. Output 1
4. Output 2
5. Pressure
6. Flow
7. Alarm 1
8. Alarm 2
9. PI Controller
10. Communication

When the desired parameter group is displayed, press the **PGM**-key to select the group for programming. The available parameters in the selected parameter group is displayed on the bottom row.

Use the arrow-keys to select which parameter to program and press the **PGM**-key.

PARAMETER LIST

Nr	Lead text	Min	Max	Default
Internals				
P00	SW: I/O			
P01	SW: OPI			
System settings				
P03	Display	dP FLOW dP+FLOW SRC+CTRL		dP
P04	Damping [s]	0,0	9,9	1,0
P05	Access code	0000	9999	0000
P06	Number of OPI	1	3	1
Output 1				
P08	Source	dP FLOW CTRL		dP
P09	Signal V	0..10 2..10		0..10
P10	Signal mA	0..20 4..20		4..20
Output 2				
P11	Source	dP FLOW CTRL		CTRL
P12	Signal V	0..10 2..10		0..10
P13	Signal mA	0..20 4..20		4..20
Pressure				
P15	MinCal [Pa]			
P16	MaxCal [Pa]			
P17	Unit dP	Pa / mbar / iwc		Pa
P18	Decimals	0	4	0
P19	Min range			MinCal
P20	Max range			MaxCal
P21	Min out	MinRange	MaxRange	MinCal
P22	Max out	MinRange	MaxRange	MaxCal
P23	Sign dP	POS / NEG		POS
P81	AutoZero [h]	0,0	60,0	0,0
Flow				
P24	Unit flow	l/s m3/s m3/h m/s cfm		l/s
P25	Decimals	0	4	0
P26	Max flow	0	32767	0
P27	Scale flw	0	32767	0
P28	Set flow	0	32767	0
Alarm 1				
P33	Mode	OFF HIGH LOW		OFF
P34	Source	dP FLOW		dP
P35	Limit	MinRange	MaxRange	0
P36	Delay [s]	0	3600	0
P37	Reset	MANUAL AUTO		AUTO
P38	Beeper	OFF ON		OFF
P39	Mute time [s]	0	3600	0
Alarm 2				
P40	Mode	OFF HIGH LOW		OFF
P41	Source	dP FLOW		dP
P42	Limit	MinRange	MaxRange	0
P43	Delay [s]	0	3600	0

Nr	Lead text	Min	Max	Default
P44	Reset	MANUAL AUTO		AUTO
P45	Beeper	OFF ON		OFF
P46	Mute time [s]	0	3600	0
PI Controller				
P47	Mode	OFF ON		OFF
P48	Source	dP FLOW		dP
P49	Set point	MinRange	MaxRange	0
P58	NZ [%]	1	50	2
P59	P-band [%]	0	100	0
P60	I-time [s]	0	999	10
P61	BZ [%]	0	100	0
P62	I-time BZ [s]	0	999	0
P63	Output	DIRECT REVERSE		REVERSE
P64	Min output [%]	0	100	0
P65	Max output [%]	0	100	100
Communication				
P73	Address	1	247	21
P74	Baud	OFF / 600	128000	38400
P75	Parity	NONE ODD EVEN		NONE
P76	Protect	NO YES		NO

Programming of a numeric value

Each digit in a numeric value is programmed separately. Press **PGM** to begin programming. The selected digit is flashing. Press the up-arrow key for digits between 1 and 9. When passing digit "9", negative digits between -9 and 0 are shown if they are allowed in the parameter value. Confirm each digit by pressing the **PGM**-key. When all digits are programmed, press the **PGM**-key to save the new value. The entire row is flashing to confirm programming. To abort ongoing programming, press the **ESC**-key and then begin a new programming with the **PGM**-key.

Note! It is always possible to abort or cancel incorrect programming using the **ESC**-key unless you have pressed the **PGM**-key after programming the last digit.

Programming of alternative units or values

Press the arrow-keys to select the desired alternative unit or value. Press the **PGM**-key to save the change. The entire row is flashing to confirm programming.

Note! It is always possible to abort or cancel incorrect programming using the **ESC**-key unless you have pressed the **PGM**-key after selected unit/value.

End programming mode

Press the **ESC**-key to return to parameter group selection display. Press the **ESC**-key a second time to close the programming menu and return to the start menu.

If no key has been pressed during 5 minutes, the program menu is closed automatically.

1. INTERNALS

Displays the program versions for the I/O-board (motherboard) and Operator Interface (display).

No	Lead text	Min	Max	Default
P00	SW: I/O			
P01	SW: OPI			

2. SYSTEM SETTINGS

General settings in MF-PFT

No	Lead text	Min	Max	Default
P03	Display	dP FLOW dP+FLOW SRC+CTRL		dP
P04	Damping [s]	0,0	9,9	1,0
P05	Access code	0000	9999	0000
P06	Number of OPI	1	3	1

- P03 *Display*, select start menu to display. Selecting 'SRC+CTRL' show the selected source (SRC) in the PI-controller + min control output signal (CTRL).
- P04 *Damping*, programme, in seconds, the damping for the pressure output signal.
- P05 *Access code*, used for activating or deactivating the code lock, see page 6.
- P06 *Number of OPI*, number of operator interfaces connected. See separate instruction.

3-4. OUTPUT 1 och OUTPUT 2

Settings for the two output signals

No	Lead text	Min	Max	Default
P08	Source	dP FLOW CTRL		dP
P09	Signal V	0..10 2..10		0..10
P10	Signal mA	0..20 4..20		4..20
P11	Source	dP FLOW CTRL		CTRL
P12	Signal V	0..10 2..10		0..10
P13	Signal mA	0..20 4..20		4..20

MF-PFT has 2 output signals which can be set to either 0..10 Volt, 2..10 Volt, 0..20 mA or 4..20 mA. Both Volt and mA are simultaneously available for both outputs.

- P08/P11 *Source*, is used to select which measuring value/signal (source) to direct as output signal. 'dP' is the pressure signal, 'FLOW' is the flow signal and 'CTRL' is the control signal from the PI-controller.
- P09/P12 *Signal V* is used to switch between 0..10 Volt and 2..10 Volt output signal.
- P10/P13 *Signal mA* is used to switch between 0..20 mA and 4..20 mA output signal.

5. PRESSURE

Settings for pressure measurement

No	Lead text	Min	Max	Default
P15	MinCal [Pa]			
P16	MaxCal [Pa]			
P17	Unit dP	Pa / mbar / iwc		Pa
P18	Decimals	0	4	0
P19	Min range			MinCal
P20	Max range			MaxCal
P21	Min out	MinRange	MaxRange	MinCal
P22	Max out	MinRange	MaxRange	MaxCal
P23	Sign dP	POS / NEG		POS
P81	AutoZero [h]	0,0	60,0	0,0

- P15/P16 *MinCal[Pa] / MaxCal[Pa]*,
The MF-PFT is factory calibrated for a specific range. The range is written on a label located on the right side of the enclosure. The calibration is always in Pascal (Pa). *MinCal* and *MaxCal* is the calibrated pressure range in Pa. These values are notes and not possible to change.
- P17 *Unit dP*, Select in which unit to display the pressure. The alternatives are Pa, mbar or iwc (inch water column).
- P18 *Decimals*, Number of decimals to show for the pressure value. When using Pa as unit it is recommended not to use decimals.
In case any set value is above 32767 regardless of where the decimal point is placed the adjustment is not carried out.
E.g. If *Set Point* = 5000 and one decimal is selected, the adjustment will not work since the value 5000,0 is greater than the allowed max value of 3276,7. Of the same reason, 500,0 cannot be adjusted to 500,00.
- P19/P20 *Min range / Max range*
When programming a new unit, min and max limits in the new unit are displayed in parameter *Min range* and *Max range*. These values are notes and not possible to change.
- P21 *Min out*, Lower limit for scaling the output signal is set in pressure units, e.g. 10 Pa will result at 10 Pa pressure the min output signal of, 0/2 V resp. 0/4 mA.
- P22 *Max out*, Higher limit for scaling the output signal is set in pressure units, e.g. 90 Pa will result at 90 Pa pressure the max output signal of 10 V resp. 20 mA.
- P23 *Sign dP*, If the transmitter is without zero crossing, the MF-PFT will indicate a negative pressure similar to positive pressure (i.e. Without negative sign). When programming *Sign dP* = 'NEG' a negative sign (-) is shown in front of the current value.
- P81 *AutoZero*, Using the optional built-in solenoid valve, automatic zero adjustment can be set. The time between adjustment can be set between 0,1 and 60 hours. During this process, the displayed values and the output signals are halted. After the zero adjustment is done in approx. 15 seconds, the transmitter restore to normal operation. Zero adjustment can also be carried out manually according to instructions on page 7.

To change the range for the output signal, the *Min out* and *Max out* are programmed. Programmed values must be in the selected unit (Pa, mbar, iwc). When scaling, be aware that the accuracy is always in percent of the factory calibrated pressure range.

6. FLOW

To measure and control the flow or velocity it is necessary to connect the transmitter to flow sensors with a known formula and k-factor.

Settings for flow measuring.

No	Lead text	Min	Max	Default
P24	Unit flow	l/s m3/s m3/h m/s cfm		l/s
P25	Decimals	0	4	0
P26	Max flow	0	32767	0
P27	Scale flw	0	32767	0
P28	Set flow	0	32767	0

- P24 *Unit flow*, select a suitable unit for flow display, l/s, m3/s, m3/h, m/s or cfm (cubic feet / minute).
- P25 *Decimals*, Number of decimals to show for the flow value. In case any set value is above 32767 regardless of where the decimal point is placed the adjustment is not carried out.

E.g. if *Max Flow* = 5000 and one decimal is selected, the adjustment will not work since the value 5000,0 is greater than the allowed max value of 3276,7. Of the same reason, 500,0 cannot be adjusted to 500,00.

- P26 *Max flow*, set the flow that correspond to the pressure range on the MF-PFT.
- P27 *Scale flw*, set the flow for max output signal, 10 V resp. 20 mA.
- P28 *Set flow*, Programme this parameter if adjusting the displayed flow is necessary. Programme the current flow using a reference flow measurement. *Max flow* is re-scaled to correspond with the reference measurement. If the unit is connected to a computer system or similar, the receiving system should also be programmed if the *Scale flw* value is higher than the new value of *Max flow*.

NOTE! Programming must be performed at the same time as when the reference value is measured (The **PGM**-key is pressed for the last digit and the value is stored).

The basic flow calculation used is made with \sqrt{dP} . To have the display and the output corresponding to the actual flow or velocity in the selected unit it is necessary to make some calculations.

Different manu factors of flow measurement devices have different calculation, but common for all is \sqrt{dP} . Use the actual formula to calculate the max flow for the factory calibrated measure range.

The calculated flow or velocity is then programmed under *Max flow* in the selected unit. E.g. 5,0 m³/s. It is possible to scale the flow range under *Scale flw*. When scaling the flow, note that the accuracy depends on the "Max flow" range. *Scale flw* must always be set to the same or a lower value than *Max flow*. E.g. 3,5 m³/s = 10 VDC.

The output signal is linear to the flow or velocity.

7-8. ALARM 1 and ALARM 2

Settings for two alarm limits.

No	Lead text	Min	Max	Default
P33	Mode	OFF HIGH LOW		OFF
P34	Source	dP FLOW		dP
P35	Limit	MinRange	MaxRange	0
P36	Delay [s]	0	3600	0
P37	Reset	MANUAL AUTO		AUTO
P38	Beeper	OFF ON		OFF
P39	Mute time [s]	0	3600	0
P40	Mode	OFF HIGH LOW		OFF
P41	Source	dP FLOW		dP
P42	Limit	MinRange	MaxRange	0
P43	Delay [s]	0	3600	0
P44	Reset	MANUAL AUTO		AUTO
P45	Beeper	OFF ON		OFF
P46	Mute time [s]	0	3600	0

MF-PFT has an alarm with two, each independent, alarm limits. The alarm is acoustic with buzzer and visual with LED (light emitting diode). Normal state is indicated with green LED and alarm state with red flashing LED on the lid. The acoustic alarm can be disabled for each alarm limit. Red LED is activated by the first alarm state that occur. At the alarm limit, the red LED is lit and after set time delay it begin to flash. The display show which of the alarm limits that triggered the alarm.

- P33/P40 *Mode*, select if the alarm should be triggered for high or low level. Programme as 'OFF' to deactivate monitoring.
- P34/P41 *Source*, Choose which measuring value to be monitored. 'dP' = pressure, 'FLOW' = flow.
- P35/P42 *Limit*, set at which level the alarm to be triggered.
- P36/P43 *Delay [s]*, set time delay before alarm state occur.
- P37/P44 *Reset*, 'MANUAL' if the alarm should be reset manually by pressing the **ESC**-key or 'AUTO' if the alarm state should return automatically to normal state when the level is back to normal.
- P38/P45 *Beeper*, 'OFF' disable the acoustic alarm. 'ON' if alarm state should sound.
- P39/P46 *Mute time*, is used to silence (mute) the alarm for a set time in seconds when the **ESC**-key is pressed. If the time is set to '0', the alarm is mute until the alarm is reset and a new alarm state occur.

9. PI-CONTROLLER

Settings of PI-controller.

No	Lead text	Min	Max	Default
P47	Mode	OFF ON		OFF
P48	Source	dP FLOW		dP
P49	Set point	MinRange	MaxRange	0
P58	Nz [%]	1	50	2
P59	P-band [%]	0	100	0
P60	I-time [s]	0	999	10
P61	BZ [%]	0	100	0
P62	I-time BZ [s]	0	999	0
P63	Output	DIRECT REVERSE		REVERSE
P64	Min output [%]	0	100	0
P65	Max output [%]	0	100	100

MF-PFT has a PI-controller specially made for pressure and flow control.

The controller could be programmed as a standard PI-controller, but in most of the applications together with pressure and flow control we recommend to program it as an integral controller without P-band.

There are two programmable I-times. Outside a desired limit on both sides of the set point it is possible to have a shorter I-time and inside the limits a longer I-time. The PI-control signal is directed to a desired output in parameter group **Output 1** or **Output 2**.

- P47 *Mode*, 'ON' activates Pi-controller, 'OFF' disable the controller.
- P48 *Source*, select which measuring value to control. 'dP' = pressure, 'FLOW' = flow.
- P49 *Set point*, Set point value in the selected unit.
- P58 *NZ [%]*, select desired neutral zone, normally 1..5%. Half zone above and half below set point value. Set in percent of the measuring range.
- P59 *P-band [%]*, normally not used for pressure or flow control, default 0%. If P-band is programmed to 0 % the P-function is disabled and the I-time is calculated for a P-band of 100%.
- P60 *I-time[s]*, set suitable I-time, normal 10s.
- P61 *BZ [%]*, Break zone, used when you want to reduce the control speed when surrounding the set point.
- P62 *I-time BZ*, set I-time inside the break zone. Enter a longer I-time for a stable control when close to the neutral zone.
- P63 *Output*, direction of the control output signal. Normally 'REVERSE' (if the pressure or flow is above set point, the output signal will decrease).
- P64 *Min output*, set a lower limit for the control output signal in %.
- P65 *Max output*, set a higher limit for the control output signal in %.

I-time

When programming as an I-controller there are two possibilities.

- The same I-time over the full range. Normally used. Program BZ = 000 and I-time BZ = 000. The I-time should normally be longer than the time for the damper motor etc. to go from min to max.

- Shifting between two I-times. The reason for working with two I-times is often that outside a set pressure or flow limit you want to have a fast response and inside a slow response (see figure below).

BZ: limit for switching I-time. BZ is in % of the scaled pressure or flow range. The set break zone, *BZ*, is counted from the neutral zone, *NZ*, higher and lower limit. The set value is on each side of the neutral zone and moves with any changes in the neutral zone. If the control output is not entering a stable position, increase the I-time, you could also try to increase the neutral zone.

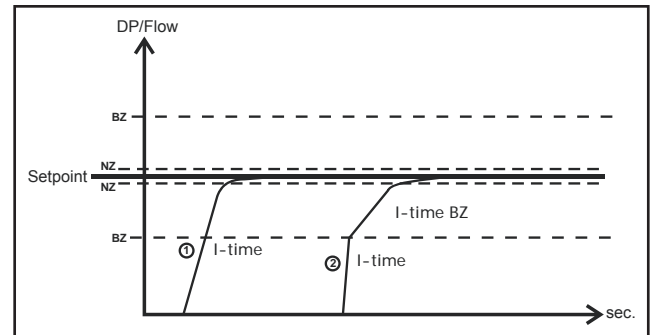

Manual operation

Return to the start menu and select the display option where output signal for PI-controller together with pressure or flow is indicated. Which one that is displayed is determined by what the PI controller is programmed for.

"Flow / dP"
"AUTO 50.00 %"

Press **PGM**, 'AUTO' changes to 'HAND' and the output signal can be set in % using the arrow keys.

Return to position 'AUTO' by pressing the **PGM**-key.

To display the programmed start menu, press the **ESC**-key.

The display showing the text "PI-" in front of 'HAND' or 'AUTO' is not possible to use for manual operation.

10. COMMUNICATION MODBUS

Modbus RTU through RS-485 serial connection.

This parameter group is only visible when communication module is installed.

No	Lead text	Min	Max	Default
P73	Address	1	247	21
P74	Baud	OFF / 600	128000	38400
P75	Parity	NONE ODD EVEN		NONE
P76	Protect	NO YES		NO

MF-PFT can be fitted with a built-in expansion module (Option) for network communication with a computer.

P73 *Address*, network address for MF-PFT, factory default as 21.

P74 *Baud*, transfer rate, factory default 38400 baud.

P75 *Parity*, Parity bit in data transfer. Factory default 'NONE'.

P76 *Protect*, Protection for parameter programming through network communication. 'YES' = write

protection. This parameter can only be set to 'NO' using the MF-PFT keypad.

CODE LOCK PROTECTION

The code lock is used to protect against an authorized programming. A four-digit code must be entered to access the program menu and the functions menu. It is still possible to read measuring values and operating state without entering the access code.

At delivery, the code is set to '0000', unless otherwise agreed on. When the code is set to '0000', the code lock is inactivated and no protection against an authorized programming is present.

Activation

To activate the code lock, a 4-digit code must be programmed in parameter P05 *Access code* which is found in parameter group **System settings**. The code can not be '0000', since this code is used to deactivate the function. When a code has been programmed and saved, the next time it will be necessary to enter the code to access the program menu and the functions menu.

Deactivating

The code lock can only be deactivated in the program menu and therefore the access code must be available to deactivate the code lock. Set the parameter P05 *Access code* to '0000'. The parameter is found in the parameter group **System settings**.

Contact Micatrone if the code has been lost!

Entering the code

To access the program menu or functions menu it is necessary to enter the access code.

Example:

1. Press the **PGM**-key to open the program menu.
Press the **PGM**-key until "PROGRAM- MENU" is displayed.
2. Release the **PGM**-key. Following text is displayed if key code is activated: "ENTER CODE:" and "0***".
3. The first digit of the access code can be entered using the arrow keys. When ready press the **PGM**-key to continue with the next digit. Repeat until all digits are entered.
4. When the 4 digits are entered, press the **PGM**-key a final time. The entered code is now compared with the programmed code in parameter P05 *Access code*. If the codes match, the program menu is displayed. The program menu is available until it has been exited using the **ESC**-key.
5. If the entered access code is incorrect, the text "INVALID CODE" is displayed during 2 seconds. Restart from point 1.
6. By pressing the **ESC**-key, the entering code operation is cancelled and the default start menu is displayed.

FUNCTIONS MENU

Functions that are not used frequently on daily basis are found in the functions menu. The functions menu is accessed by pressing simultaneously the **PGM** and **ESC**-key until the text "FUNCTIONS-MENU" is displayed. If code lock is activated, see page , a valid access code must be entered to access the menu. Use the arrow keys to scroll through the different functions, when displayed, select the desired function by pressing the **PGM**-key. Exit the present menu by pressing the **ESC**-key.

Functions

- *Serial number* Display the serial number xxxxx-xxx.
- *Date of cal.* Display the latest factory calibration date.
- *Reset Defaults* Restore all data to the latest factory calibration.
- *List of params* All values in the entire parameter list is restored to default values at factory delivery.
- *Calibrations* All calibrations is restored to the original values at factory delivery.
Note: field calibrations will be reset .
- *Calibration*
 - *Input*, five-point calibration of the pressure measurement
- *Statistics* Displays statistics for internal restarts.
 - *Power on*, Number of normal power-on's.
 - *Brown out*, Number of restarts due to poor supply voltage.
 - *Watchdog reset*, Number of restarts due to runtime error.
 - *SW error reset*, Number of restarts due to software error.
 - *Last reset cause*, The cause for the latest restart.
 - *Operting time*, Operting time since latest start. Shown in days, hours and minutes (d:hh:mm).

Zero setting of pressure transmitter

Disconnect the pressure connections or place the block valve in position calibration.

Press repeatedly on the **ESC**-key until the start menu is displayed.

Press simultaneously on both arrow keys, keep pressed until the display show:



ZERO OFFSET

Release the keys when following is shown:



ZERO OFFSET
ADJUSTING

When the zero setting is done, the display show:



ZERO OFFSET
DONE

Followed with the start menu.

If the transmitter is equipped with built-in auto zero module, manual zero setting is done using the arrow keys without the need to detach any tubes or changing position of a connected mono block valve.

Calibration of MF-PFT

MF-PFT can be re calibrated against a pressure reference.

1. Keep **PGM** and **ESC** pressed until following text is displayed: "FUNCTIONS-MENU".
2. Scroll using the arrow keys until "Calibration" is displayed.
3. Press **PGM**. "Input" is shown.
4. Press **PGM**. "Cal dP" is shown.
5. Press **PGM**. The first calibration point is shown.
Example:
MF-PFT (-50..50 Pa)
Pnt 1(5) = -50
6. Connect shown pressure. In this case, 50 Pa, to the pressure connection marked negative [-].
7. Press the **PGM**-key and the MF-PFT will start to measure the first calibration point (9 measurements).
8. Press the **PGM**-key to continue with the second calibration point, **ESC** aborts the calibration.
9. Proceed with all five calibration points and be careful to connect to the correct pressure connection.
10. When all calibration points are done, following text is shown:
"PGM=OK/ESC=ABORT"
11. The **PGM**-key will confirm the calibration and store the new calibration values.
12. The **ESC**-key will abort and cancel the calibration. Press repeatedly on the **ESC**-key to return to the start menu again.

Note! The pressure reference should comply with the demand of desired accuracy in the measurement.

TECHNICAL DATA:

Display: Alphanumeric LCD
2 row, 2x16 characters
with backlight

Power supply: 24 ± 15% VAC
20...32 VDC

Pwr consumption: Max 3 VA (24VAC)

Pressure range: see label on enclosure.
Flow range:
(max 4 decimals)
l/s 0...32767
m3/s 0...32767
m3/h 0...32767
m/s 0...32767
cfm 0...32767

Measurement error: < ± 0,5 % of the pressure
range ± 0,5 Pa

Temperature drift: < ± 0,5 % /10 °C

Damping: 0,0...9,9 sec.

Output signal: Two analogue outputs,
0/2...10 VDC, 0/4...20 mA
selectable and scalable.
Both mA and Volt output
can be used simultaneously

Ambient temp: 0...50°C

Alarm: Two separate alarms for
high & low level, alarm
indication with red LED and
buzzer (joint)

Degree of protection: IP 65, ABS plastic

EI-connection: 1 x 2,5 mm² / terminal

Cable entries: 4 pcs M16x1.5mm
(cable glands not included)

Dimensions: WxHxD = 122x120x90 mm

Weight: 0,81 kg

MAINTENANCE:

Check zero settings every 6.th. month.

ACCESSORIES:

- Mounting kit for recessed mounting,
MFM-PANEL
- External transformer 24, 115, 230 VAC
- MODBUS communication module
- Solenoid valve for automatic zero-adjustment.

EMC/LVD:

Applied EU directives:

- EMC SS-EN 61000-6-3:2007 + A1:2011
SS-EN 61000-6-2:2005 + C1:2005
- LVD SS-EN 61010-1:2010

ELECTRICAL CONNECTION:

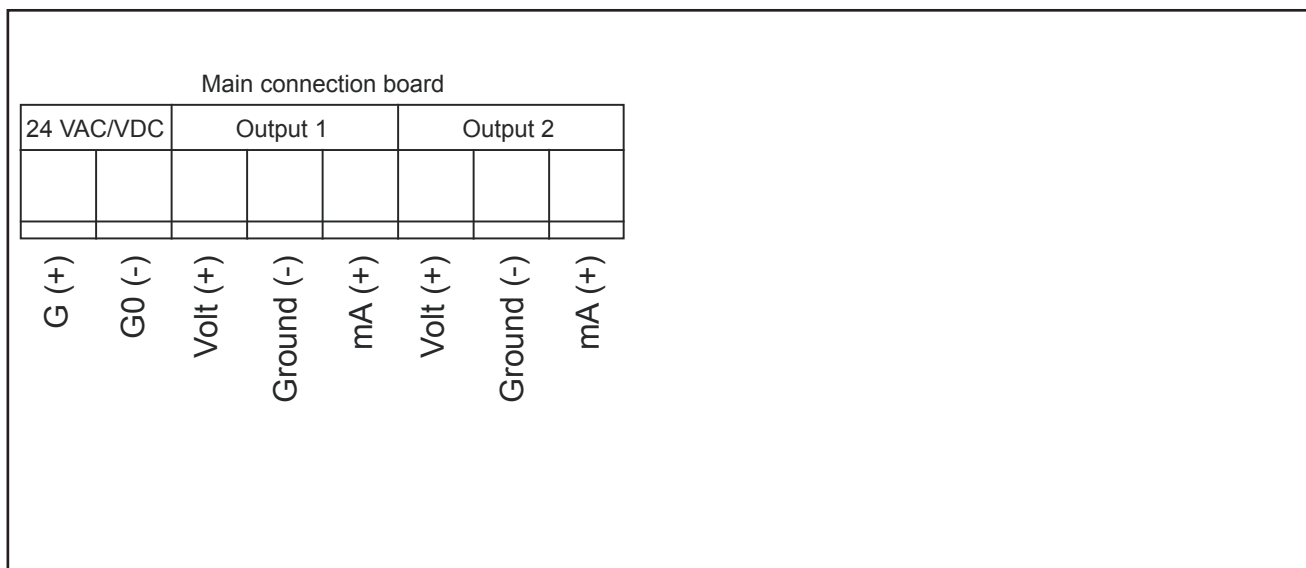

AB Micatrone
Aldermansvagen 3
SE-171 48 SOLNA
SWEDEN

Telephone: +46-8-470 25 00
Fax: +46-8-470 25 99
Internet: www.micatrone.se
E-mail: info@micatrone.se