



Series K . K40-C1

Impulse counter, ratemeter

PANEL METERS

Impulse counter, ratemeter and periodmeter, with 20 mm digit height. Accepts all type of impulse sensors (NPN, PNP, Namur, TTL, inductive, mechanical, encoders, ...). Provides configurable excitation voltage to power-up the transducer. Standard 96x48 mm size (1/8 DIN). Reading with 4 digit display. Fast access to alarm setpoints, special modes for fast counting and for slow ratemeter applications, 'on power up' function, configurable reading brightness. Universal AC and DC power. Up to 3 optional modules for output and control (relays, analog outputs, Modbus RTU communications, RS-485 ASCII, RS-232, ...)

www.fema.es

Tel. (+34) 93.729.6004 info@fema.es

1. Panel meter K40-C1

Counter, ratemeter and periodmeter, 96x48mm (1/8 DIN), with 20 mm digit height

Panel meter 96x48mm (1/8 DIN) and 4 digits with 20mm digit height, configurable with 5 impulse counter modes (see section 1.2), 2 ratemeter modes (see section 1.3) and a 1 periodmeter mode (see section 1.4).

Highly configurable, accepts all types of sensors (NPN, PNP, push-pull, Namur, inductive, pick-up, mechanical, TTL, CMOS, ...) including quadrature signals (single and bidirectional encoder signals).

Reading from 9999 to -1999 with decimal point, scalable reading with configurable multiplier factor (1 to 9999) and configurable divider factor (1 to 9999). Includes internal pull-up and pull-down resistors, configurable trigger levels, detection by rising or falling edge, excitation voltage configurable from 5 Vdc to 18 Vdc.

Options for output and control with 1, 2 and 3 relays, isolated analog outputs, communications in Modbus RTU, RS-485 ASCII and RS-232. Special options with 4 and 6 relay outputs.

Independent alarms configurable as maximum or minimum, with 1 or 2 setpoints per alarm, hysteresis, independent activation and deactivation delays and control for inverted relay.

Front protection IP54 with optional IP65. Connections by plug-in screw terminals. For industrial applications.

- 'Fast access' menu to selected functions, accessible with key UP (▲) (see section 1.19.12)
- Function 'On power up' for system protection on first 'cold' start-up or automatic reset (see section 1.19.14)
- Special 'FAST' mode for fast counting applications (see section 1.16)
- Special 'SLOW' mode for slow ratemeter applications (low frequency applications) (see section 1.15)
- Direct configuration for most usual sensor, at the 'SnSr / Auto' menu (see section 1.19.10)
- Function 'Trigger Sense' helps to detect the correct trigger level (see section 1.13)

Multiple display filters, memory for maximum and minimum reading, password protection, 5 brightness levels.

Index

1. Panel meter K40-C1	2	1.19.14 Menu 'On Power Up'	14
1.1 How to order	3	1.19.15 Menu 'Key LE'	15
1.2 Impulse counter modes	3	1.19.16 Menus 'Overrange / underrange'	15
1.3 Ratemeter modes	3	1.19.17 Left zeros	15
1.4 Periodmeter mode	3	1.19.18 Function 'Password'	15
1.5 Functions included	3	1.19.19 Factory reset	15
1.6 Front view	4	1.19.20 Firmware version	15
1.7 Power connections	4	1.19.21 Brightness	15
1.8 Sensor configuration and connections	4	1.19.22 Access to optional modules	15
1.9 Vista posterior	4	1.20 Full configuration menu	16
1.10 Signal connections	4	1.21 Factory configuration	19
1.11 Technical specifications	5	1.22 To access the instrument	20
1.12 Mechanical dimensions (mm)	5	1.23 Modular system	20
1.13 Function 'Trigger Sense'	6	1.24 Precautions on installation	21
1.14 Function 'cycle counter'	6	1.25 Warranty	21
1.15 'SLOW' mode	6	1.26 CE declaration of conformity	21
1.16 'FAST' mode	6	2. Output and control modules	22
1.17 How to operate the menus	7	2.1 Module R1	22
1.18 Messages and errors	7	2.2 Module AO	22
1.19 Configuration menu	8	2.3 Module RTU	23
1.19.1 Initial set-up	8	2.4 Module S4	23
1.19.2 Configuration for 'cn.1'	8	2.5 Module S2	24
1.19.3 Configuration for 'cnq.2'	9	2.6 Modules R2, R4, R6	24
1.19.4 Configuration for 'cni.3'	9	3. Other options	26
1.19.5 Configuration for 'cnc.4'	9	3.1 Option NBT	26
1.19.6 Configuration for 'cnd.5'	10	3.2 Option IP65	26
1.19.7 Configuration for 'rt.6'	10	4. Accessories	27
1.19.8 Configuration for 'rtq.7'	10	4.1 THM benchtop housing	27
1.19.9 Configuration for 'Prd.8'	11	4.2 Adapter KA96	27
1.19.10 Sensor configuration	11	4.3 Adapter DRA-M	27
1.19.11 Alarms	13	4.4 Protector IP65	27
1.19.12 Fast access	14		
1.19.13 Super fast access	14		

1.1 How to order

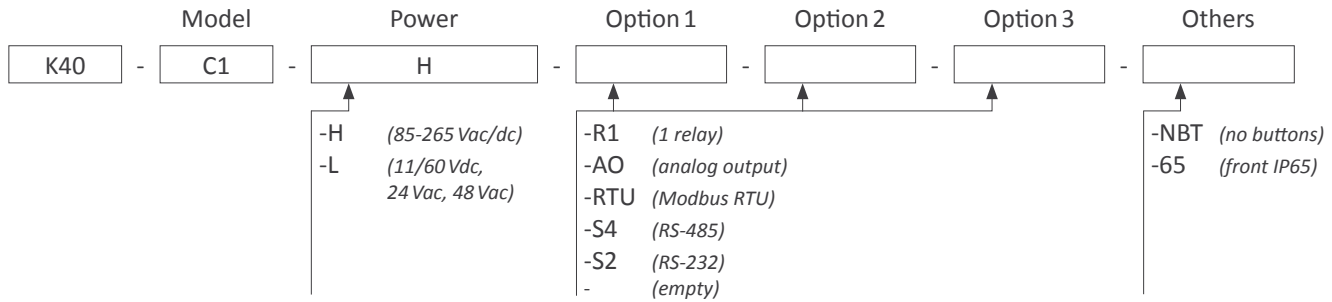

1.2 Impulse counter modes

The instrument allows for 5 selectable impulse counter modes :

- Counter ('**cn.1**') (see section 1.19.2)
- Counter quadrature ('**cnq.2**') (see section 1.19.3)
- Counter with inhibition ('**cnl.3**') (see section 1.19.4)
- Counter with control add / subtract ('**cnc.4**') (see section 1.19.2)
- Counter differential ('**cnd.5**') (see section 1.19.6)

Configurable up or down counting, 'reset' at rear terminals, front key and/or at alarm activation. Configurable 'Preset' value. Relay activation and deactivation delays.

Alarm functions with 'return to preset' or 'reset to 0' generate cycles of counting (instrument counts from 'preset' value to alarm value in never ending cycle). The instrument provides memory of cycles counter.

Scalable reading with configurable multiplier factor (1 to 9999) and configurable divider factor (1 to 9999). Memory retention in case or power loss. Retains configuration and last reading.

Counting frequency up to 250 KHz, in '**FAST**' mode (see section 1.16).

1.3 Ratemeter modes

In ratemeter mode the reading is proportional to the measured frequency. The instrument allows for 2 selectable ratemeter modes :

- Ratemeter ('**rt.6**') (see section 1.19.7)
- Ratemeter quadrature ('**rtq.7**') (see section 1.19.8)

The ratemeter mode has a single input channel, with scalable reading. The quadrature ratemeter mode has 2 input channels available for detection of sense of turn when working with quadrature signals. Scalable reading with configurable multiplier factor (1 to 9999) and configurable divider factor (1 to 9999).

For low frequency applications, the '**SLOW**' mode provides the best response time for each application (see section 1.15).

Maximum frequency up to 900 KHz and minimum frequency down to de 0.001 Hz (1 mHz) with '**SLOW**' mode active.

1.4 Periodmeter mode

Reading is proportional to the signal period. Scalable reading with configurable multiplier factor (1 to 9999) and configurable divider factor (1 to 9999).

For applications with long periods (slow frequencies), the '**SLOW**' mode provides the best response time for each application (see section 1.15).

1.5 Functions included

Functions included		Section
'Fast access'	yes	1.19.12
'SLOW' mode	yes, for slow frequencies	1.15
'FAST' mode	yes, for fast counting	1.16
Multiplier and divider	from 1 to 9999	1.19.2
Reset configurable	yes (front, rear and linked to alarm activation)	1.19.15 and 1.10 and 1.19.11
Preset	yes	1.19.2
Trigger level	configurable	1.19.10
'Trigger Sense' function	helps to set the trigger	1.13
Sensor selection	by menu	1.19.10
Cycle counter		1.14
Retention memory	yes, recovers with power	1.11
'On Power Up'	yes	1.19.14
Excitation voltage	configurable	1.19.10
Display filters	recursive	1.19.7 and 1.19.8 and 1.19.9
Memory	max., min., cycles	1.19.12
Password	blocks access to configuration menu	1.19.18
Alarms	double setpoints activation delays deactivation delays hysteresis inverted relays locked alarms	1.19.11
Display brightness	5 levels	1.19.21

Table 1 - Functions included

1.6 Front view

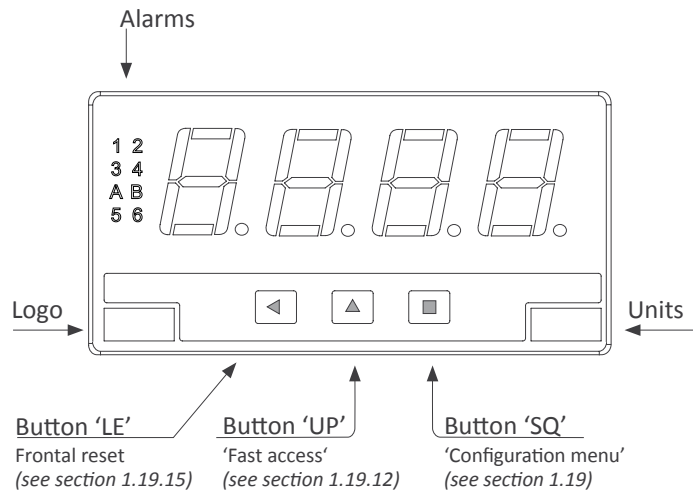

1.9 Rear view

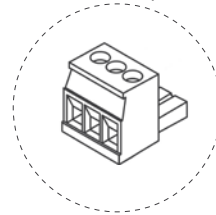
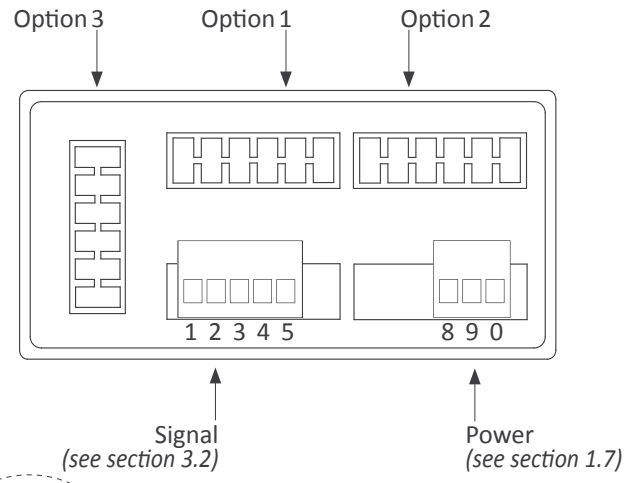

Detail of the plug-in screw terminals provided with the instrument. The instrument is provided with all terminals needed, both male and female.

1.7 Power connections

Earth connection - Although a terminal is provided for earth connection, this connection is optional. The instrument does not need earth connection for correct operation nor for compliance with the security regulations.

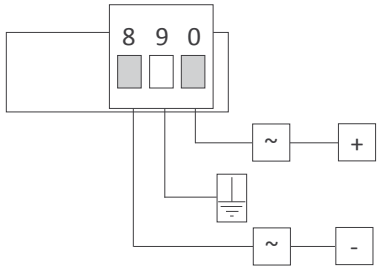

Fuse - To comply with security regulation 61010-1, add to the power line a protection fuse acting as disconnection element, easily accessible to the operator and identified as a protection device.

- Power 'H' fuse 250 mA time lag
- Power 'L' fuse 400 mA time lag

1.10 Signal connections

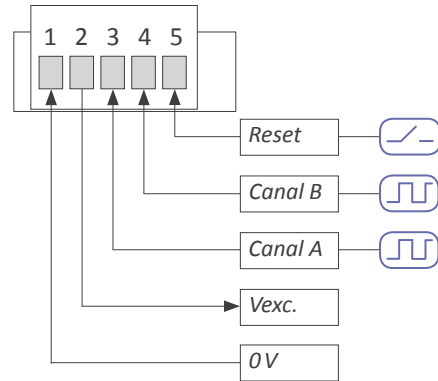

1.8 Sensor configuration and connections

Selecting one of the sensors listed at the 'SnSr' menu entry, will configure the sensor parameters to the values indicated in the table.

The table also indicates the typical connections for each type of sensor. Parameters can be manually modified.

Connections are indicated for a single sensor connected to the channel A. For two sensors (for inhibition control, quadrature signal, etc) apply the same connection criteria also to channel B.

Note : indicated values are typical values. Check the correct specifications with your sensor datasheet and adapt the required configuration and connections as needed.

Sensor	Connections	Pulls	Vexc.	Antirrebound filter	Trigger
Mechanical contact	0V channel A	pull-up	no	100 mSec.	2,5 Vdc
Namur	channel A Vexc	pull-down	9 Vdc	no	3,0 Vdc
NPN 2 wires	0V channel A	pull-up	18 Vdc	no	2,5 Vdc
NPN 3 wires	0V channel A Vexc	pull-up	18 Vdc	no	2,5 Vdc
PNP 2 wires	0V channel A	pull-down	18 Vdc	no	2,5 Vdc
PNP 3 wires	0V channel A Vexc	pull-down	18 Vdc	no	2,5 Vdc
Push-pull	0V channel A Vexc	no	18 Vdc	no	2,5 Vdc
TTL CMOS Pick-up	0V channel A	no	5 Vdc	no	2,5 Vdc
AC<30Vp Inductive	0V channel A	no	no	no	0 Vdc

Table 2 - Configuration and connections for different types of sensors.

1.11 Technical specifications

Digits

number of digits	4
led	7 segments led
color	red
digit height	20 mm

Reading

maximum reading	9999
minimum reading	-1999
decimal point	configurable X.X.X.X.
overrange / underrange	configurable to flash, reset or preset (see section 1.19.16)
display refresh	15 readings / second
memory retention	yes, retains reading value in case of power loss

Signals accepted

NPN, PNP, Namur, pick-up, TTL, inductive, mechanical, quadrature, ...

Max. Vdc at input

±30 Vdc

Input impedance

2K4 with pull-up or pull-down resistor
470K without pull resistor

Accuracy of the quartz

±0.01 %

Thermal drift

20 ppm / °C

Excitation voltage

configurable

output voltage

+18 Vdc, +15 Vdc, +9 Vdc, +5 Vdc

maximum current

70 mA

protection

yes, current limited to 70 mA

Frequencies

counter modes (see Table 3)

ratemeter modes (see Table 4)

periodmeter modes (see Table 5)

Power

power 'H'

85 to 265 Vac/dc

power 'L'

11 to 60 Vdc and 24/48 Vac

isolation*

3500 Veff with power 'H'

2000 Veff with power 'L'

*tested for 60 sec.

consumption

<1.5 W only meter

<4.0 W meter with options

Configuration

3 buttons front keypad

Front protection

IP54 standard

IP65 optional (see section 3.2)

Output and control options

relays, analog outputs, serial communications (see section 2)

Mechanical

mounting

panel

connections

plug-in screw terminal

housing material

ABS, polycarbonate (V0)

weight

<150 grams

front size

96 x 48 mm (1/8 DIN)

panel cut-out

92 x 44 mm

depth from panel

91 mm (including terminals)

Temperature

operation

from 0 to +50 °C

storage

from -20 to +70 °C

warm-up time

15 minutes

Counter	Mode	Frequency	Section
Counter	'FAST' mode	max. 250 KHz	1.16
	normal mode	max. 9 KHz	1.19.2
Counter + inhibition		max. 9 KHz	1.19.4
Counter + control A/S		max. 9 KHz	1.19.5
Counter differential		max. 9 KHz	1.19.6
Counter quadrature	mode x1	max. 17 KHz	1.19.3
	mode x2	max. 16 KHz	1.19.3
	mode x4	max. 11 KHz	1.19.3

Table 3 - Maximum input frequency for counter modes

Ratemeter	Mode	Frequency	Section
Ratemeter	normal mode	max. 900 KHz	1.19.7
	SLOW' mode	max. 200 KHz min. 1 mHz	1.15
Ratemeter quadrature	mode x1	max. 17 KHz	1.19.8
	mode x2	max. 16 KHz	1.19.8
	mode x4	max. 11 KHz	1.19.8

Table 4 - Maximum and minimum input frequency for ratemeter modes

Periodmeter	Mode	Frequency	Section
Periodmeter	normal mode	max. 900 KHz	1.19.9
	SLOW' mode	max. 200 KHz min. 1 mHz (1000 sec.)	1.19.9

Table 5 - Maximum and minimum input frequency for periodmeter modes

1.12 Mechanical dimensions (mm)

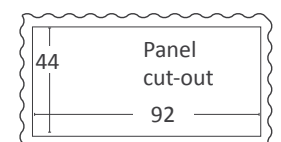
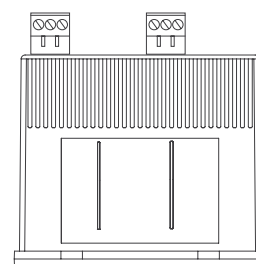
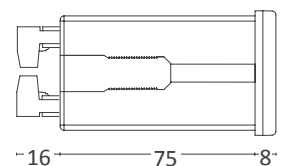
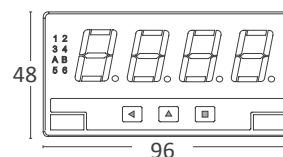

1.13 Function 'Trigger Sense'

The trigger level is automatically configured when selecting a sensor from the 'Sensor / Configuration' ('SnSr' / 'Auto') menu list. The trigger level can be also manually modified from the 'SnSr' / 'TRIG' menu entry. The selected value applies to channels 'A' and 'B' (the reset has a fixed trigger level at 2.5 Vdc).

At the 'SnSr' / 'TRIG' menu, the instrument shows the trigger level and two vertical leds to the left. These leds inform in real time about the status ('0' or '1') of the input channels 'A' and 'B'. When the led switches between up and down position, it indicates that impulses are being detected at the input. If the instrument does not detect impulses, the led positions remain fixed..

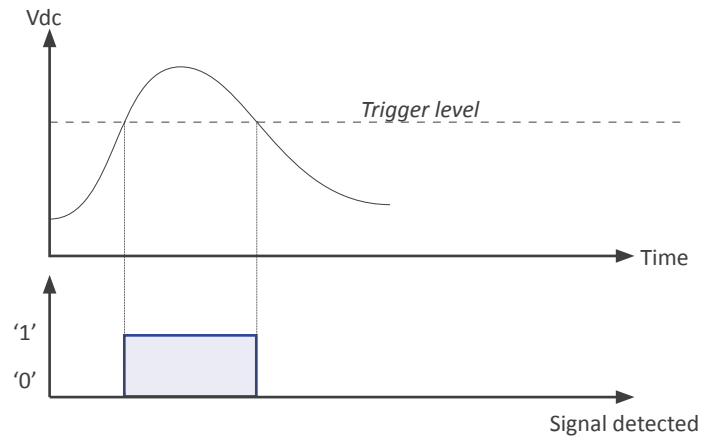
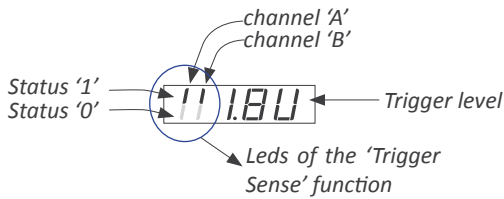

1.14 Function 'cycle counter'

The counter modes allow to activate a reset function (to '0' or to 'preset' value) when an alarm setpoint is reached. With this configuration, the instrument counts in cycles, counting from the instrument preset value up to the alarm setpoint. Each cycle is counted and accumulated into an internal memory, accessible through the 'fast access' menu (key UP (▲) (see section 1.19.12)).

To reset the memory of cycles, visualize the value at the 'uP' menu, then press the (▲) key and the 'rSt' message appears. Press (■) to reset.

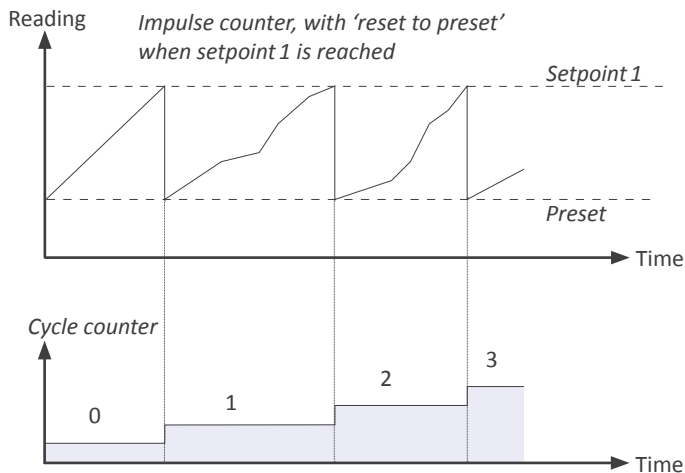

1.15 'SLOW' mode

Special working mode for applications with low frequency signals. Applies to ratemeter ('rt.6'), ratemeter quadrature ('rtq.7') and periodmeter ('Prd.8'). The 'SLOW' mode allows to measure slow frequencies down to 1 mHz (0,001 Hz) and is functional up to 200 Hz.

The 'SLOW' mode provides the fastest response time possible for a given application, calculating the frequency and the period based on the time between consecutive impulses.

The 'SLOW' mode needs to define the parameter 'maximum waiting time' to a value between 1 and 1000 seconds. If this time expires without a single impulse being received, the reading jumps to '0' (both for ratemeter and periodmeter modes). The 'GATE' parameter is not used if 'SLOW' mode is active.

In 'ratemeter quadrature' ('rtq.7') mode, the activation of the 'SLOW' mode calculates the frequency based on the time between consecutive impulses received on channel A, and calculates the sense of turn (clockwise or counter-clockwise) by comparing each impulse with the state of channel B. The 'edge' parameter is fixed to a '1--1'. Typical application for quadrature frequency measure with two inductive sensors at low frequency.

1.16 'FAST' mode

Special working mode for counter applications with high frequency signals, up to 250 KHz. Applies only to the counter mode ('cn.1').

The activation of the 'FAST' mode configures the signal detection by rising edge. The first edge detected, either rising or falling edge, after the instrument restart (power-up, or configuration change) is used for internal initialization and will not be counted as impulse.

1.17 How to operate the menus

The instrument has two menus accessible to the user :

'Configuration menu' (key SQ) (■)

'Fast access' menu (key UP) (▲)

Configuration menu

The 'configuration menu' modifies the configuration parameters to adapt the instrument to the application needs. To access the 'configuration menu' press for 1 second the SQ (■) key. This access can be blocked by activating the 'Password' ('PASS') function. While operating the 'configuration menu', the alarm status is 'hold' to the status they had before accessing the menu, and the output and control modules remain in 'error' state. When leaving the 'configuration menu', the instrument applies a system reset, followed by a brief disconnection of the alarms and the output and control modules. Functionality is then recovered.

For a detailed explanation on the 'configuration menu' see section 1.19, and for a full view of the 'configuration menu' structure see section 1.20.

'Fast access' menu

The 'fast access' menu is an operator configurable menu, providing fast and direct access to the most usual functions of the instrument with a single key pad stroke. Press key UP (▲) to access this menu.

See section 1.19.12 for a list of functions eligible for 'fast access' in this instrument. The 'Password' ('PASS') function does not block access to this menu. Accessing and modifying parameters in the 'fast access' menu does not interfere with the normal functionality of the instrument, and it does not generate any system reset when validating the changes.

Front key pad description

Key SQ (■) - press the SQ (■) key for 1 second to access the 'configuration menu'. Inside the menu, the SQ (■) key functions as a 'ENTER' key. It selects and accesses the menu option currently displayed. At menus with numerical value entries, it validates the number displayed.

Key UP (▲) - the UP (▲) key gives access to the 'fast access' menu. Inside the menus, it moves vertically through the different menu options. At menus with numerical value entries, it modifies the digit selected by increasing its value to 0, 1, 2, 3, 4, 5, 6, 7, 8, 9.

Key LE (◀) - inside the menus, the LE (◀) key functions as the 'ESCAPE' key. It leaves the selected menu, and eventually, will leave the whole menu. When leaving the 'configuration menu' with the LE (◀) key, the changed parameters are activated. At menus with numerical value entries, the LE (◀) key allows to select the active digit. To modify the value of the selected digit use the UP (▲) key.

Menu 'rollback'

After 30 seconds without interaction from the operator, the instrument will rollback and leave the 'configuration menu' or the 'fast access' menu. All changes will be discarded.

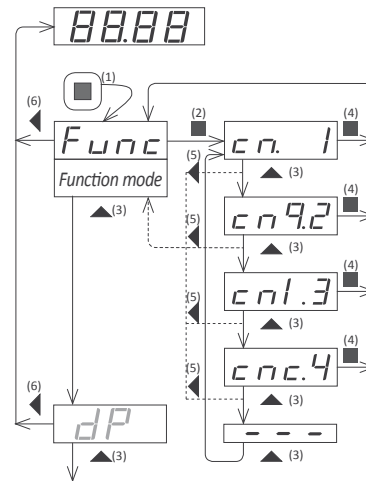

Example of operation inside the 'configuration menu'.

1. The SQ (■) key enters into the 'configuration menu'.
2. The SQ (■) key enters into the 'Func' option menu.
3. The UP (▲) key moves through the menu options.
4. The SQ (■) key selects the desired range and returns to the 'Func' menu.
5. The LE (◀) key leaves the actual menu level and moves to the previous menu level.
6. The LE (◀) key leaves the 'configuration menu'. Changes are applied and saved at this moment.

1.18 Messages and errors

The error messages are shown on display in flash mode.

Messages and errors	
'Err.1'	incorrect password.
'Err.2'	at 'oPt.X' menu entry. Installed module is not recognized.
'Err.8'	excitation voltage overload.
'9999'	+ flashing mode. Reading is in overrange.
'-1999'	+ flashing mode. Reading is in underrange.

Table 6 - Messages and error codes

1.19 Configuration menu

Press 'SQ' (■) for 1 second to access the 'configuration menu'. For a description on how to operate inside the menus see section 1.17. For a full vision of the 'configuration menu' structure see section 1.20.

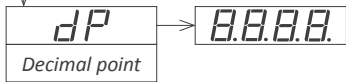
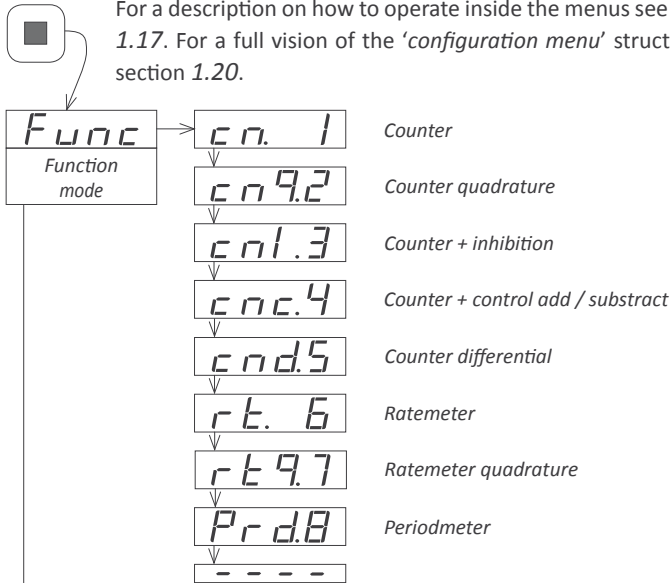

The next menu accesses the configuration parameters for the 'function mode' ('Func') selected. Configuration parameters are slightly different for each 'function mode'. In the next entries, all 7 possible configuration menus are explained, 'cnF.1' to 'cnF.7', one for each 'function mode'.

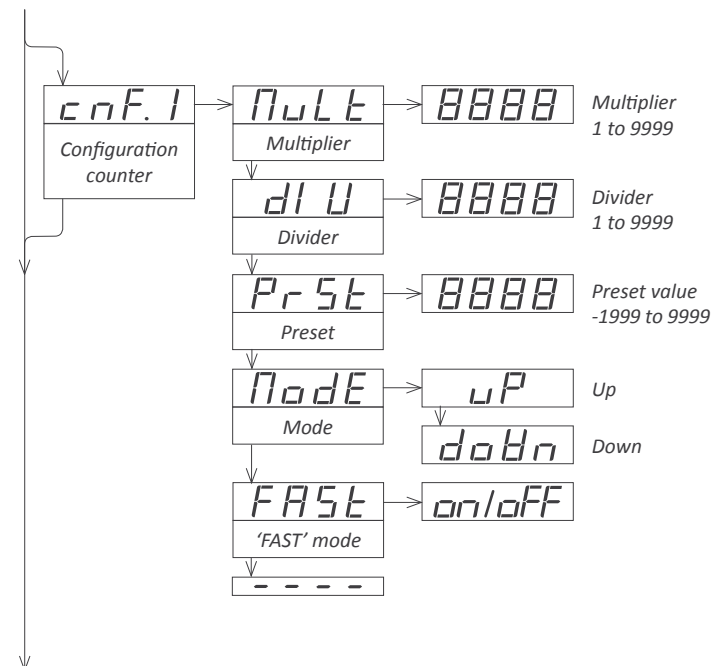

1.19.1 Initial set-up

To configure the initial set up of the instrument, select the function mode, the decimal point position, scale the reading and configure the mode selected and the sensor.

Enter the 'Function mode' ('Func') menu and select the desired function, from the 5 counting modes, 2 ratemeter modes and the periodmeter mode available.

- **'Counter' ('cn. 1')** - normal counter mode. Impulses input at channel A. Channel B disabled.
- **'Counter quadrature' ('cnq.2')** - counter mode for quadrature signals. Impulses input at channel A and B, in quadrature.
- **'Counter + inhibition' ('cni.3')** - counter mode with inhibition control. Impulses input at channel A. Inhibition control on channel B.
- **'Counter + control add / subtract' ('cnc.4')** - counter mode with control for add / subtract. Impulses input at channel A. Control for the add or subtract function on channel B.
- **'Counter differential' ('cnd.5')** - counter mode with differential function. Impulses received at channel A add. Impulses received at channel B subtract.
- **'Ratemeter' ('rt.6')** - ratemeter mode. Impulses input at channel A. Channel B disabled.
- **'Ratemeter quadrature' ('rtq.7')** - ratemeter mode for quadrature signals. Impulses input at channel A and B, in quadrature.
- **'Periodmeter' ('Prd.8')** - periodmeter mode. Impulses input at channel A. Channel B disabled.

Access the 'Decimal point' ('dP') menu to select the decimal point position. Move the decimal point by pressing the 'LE' (◀) key.

Configure the function mode selected ('cnF.2' to 'cnF.8'). See sections 1.19.2 to 1.19.9.

Configure the sensor at the 'SnSr' menu. See section 1.19.10.

1.19.2 Configuration for 'cn.1'

Configuration menu for mode 'counter' ('cn.1'). Total impulses received are multiplied by the value of the 'multiplier' ('MuLt') register and divided by the 'divider' ('dIV') register. Result is refreshed on the display.

- assign the value for parameter 'Multiplier' ('MuLt') from 1 to 9999.
- assign the value for parameter 'Divider' ('dIV') from 1 to 9999.
- assign the value for 'Preset' ('PrSt') from -1999 to 9999. Reset activation loads on display the preset value.
- select the counting mode ('MoDE') to 'uP' for upwards counting (impulses received add) or 'doWn' for downwards counting (impulses received subtract).
- to activate the 'FAST' mode ('FAST') select 'on'. See section 1.16 for more information on the 'FAST' mode.

1.19 Configuration menu (cont.)

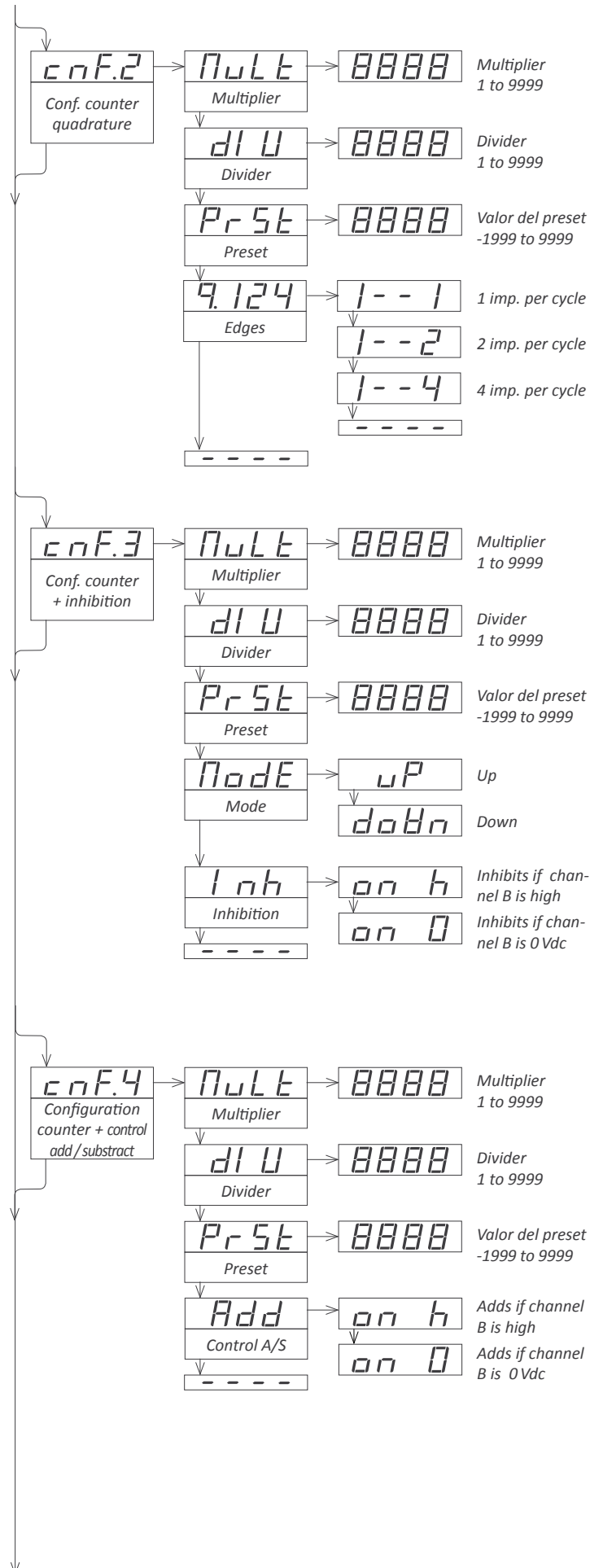

1.19.3 Configuration for 'cnq.2'

Configuration menu for mode 'counter quadrature' ('cnq.2'). Total impulses received are multiplied by the value of the 'multiplier' ('MuLt') register and divided by the 'divider' ('dIV') register. Result is refreshed on the display.

- assign the value for parameter 'Multiplier' ('MuLt') from 1 to 9999.
- assign the value for parameter 'Divider' ('dIV') from 1 to 9999.
- assign the value for 'Preset' ('PrSt') from -1999 to 9999. Reset activation loads on display the preset value.
- select the 'edges' to count for each quadrature cycle ('q.124'). Select '1--1' for 1 impulse per quadrature cycle. Select '1--2' for 2 impulses per quadrature cycle. Select '1--4' for 4 impulses per quadrature cycle.

1.19.4 Configuration for 'cni.3'

Configuration menu for mode 'counter + inhibition control' ('cni.3'). Total impulses received are multiplied by the value of the 'multiplier' ('MuLt') register and divided by the 'divider' ('dIV') register. Result is refreshed on the display.

- assign the value for parameter 'Multiplier' ('MuLt') from 1 to 9999.
- assign the value for parameter 'Divider' ('dIV') from 1 to 9999.
- assign the value for 'Preset' ('PrSt') from -1999 to 9999. Reset activation loads on display the preset value.
- select the counting mode ('ModE') to 'uP' for upwards counting (impulses received add) or 'doWn' for downwards counting (impulses received subtract).
- select the activation mode for the 'inhibition' ('Inh') control. Select 'on_h' to inhibit the counting when channel B is at logical state '1'. Select 'on_0' to inhibit the counting when channel B is at logical state '0'.

1.19.5 Configuration for 'cnc.4'

Configuration menu for mode 'counter + control add/subtract' ('cnc.4'). Total impulses received are multiplied by the value of the 'multiplier' ('MuLt') register and divided by the 'divider' ('dIV') register. Result is refreshed on the display.

- assign the value for parameter 'Multiplier' ('MuLt') from 1 to 9999.
- assign the value for parameter 'Divider' ('dIV') from 1 to 9999.
- assign the value for 'Preset' ('PrSt') from -1999 to 9999. Reset activation loads on display the preset value.
- select the activation mode for the 'control add/subtract' ('Add'). Select 'on_h' activates the addition of impulses received on channel A when channel B is at logical state '1' (impulses on channel A subtract if channel B is at logical state '0'). Select 'on_0' activates the addition of impulses received on channel A when channel B is at logical state '0' (impulses on channel A subtract if channel B is at logical state '1').

1.19 Configuration menu (cont.)

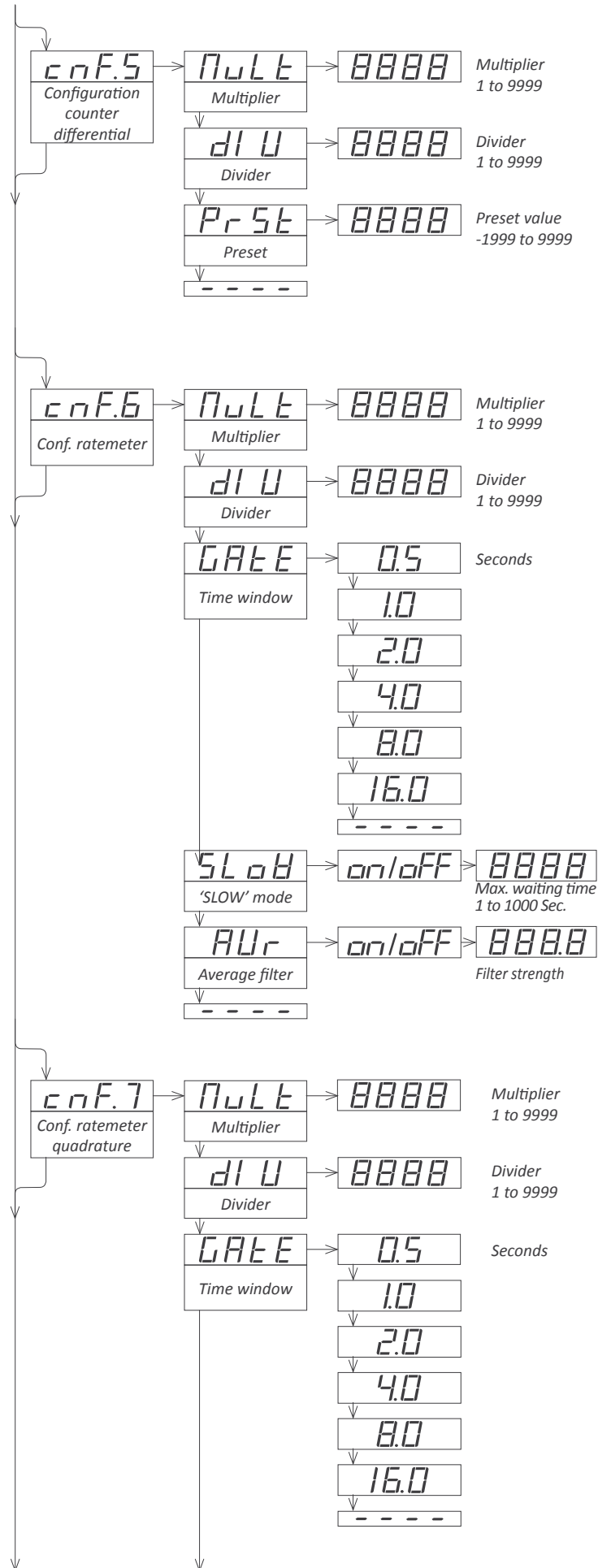

1.19.6 Configuration for 'cnd.5'

Configuration menu for mode 'counter differential' ('cnd.5'). Total impulses received are multiplied by the value of the 'multiplier' ('MuLt') register and divided by the 'divider' ('dIV') register. Result is refreshed on the display.

- assign the value for parameter 'Multiplier' ('MuLt') from 1 to 9999.
- assign the value for parameter 'Divider' ('dIV') from 1 to 9999.
- assign the value for 'Preset' ('PrSt') from -1999 to 9999. Reset activation loads on display the preset value.

Impulses received on channel A add. Impulses received on channel B subtract.

1.19.7 Configuration for 'rt.6'

Configuration menu for mode 'ratemeter' ('rt.6'). Frequency measured is multiplied by the value of the 'multiplier' ('MuLt') register and divided by the 'divider' ('dIV') register. Result is refreshed on the display. Measure is updated at the rate defined on the 'GATE' register.

- assign the value for parameter 'Multiplier' ('MuLt') from 1 to 9999.
- assign the value for parameter 'Divider' ('dIV') from 1 to 9999.
- select the value for the 'Time window' ('GAtE'). Available values are : 0.5, 1.0, 2.0, 4.0, 8.0 or 16.0 seconds. The time window defines the display refresh time. This parameter has no effect if the 'SLOW' mode is active.
- for slow frequencies, activate the 'SLoW' mode and assign the 'Maximum waiting time' between 1 and 1000 seconds. See section 1.15 for more information on the 'SLoW' mode.
- in case of unstable signals, activate the 'average filter' ('AVr') function. It activates a recursive filter on the reading. the filter is stronger for higher values, from 0.0 to 99.9.

1.19.8 Configuration for 'rtq.7'

Configuration menu for mode 'ratemeter quadrature' ('rtq.7'). Frequency measured is multiplied by the value of the 'multiplier' ('MuLt') register and divided by the 'divider' ('dIV') register. Result is refreshed on the display. Measure is updated at the rate defined on the 'GATE' register.

- assign the value for parameter 'Multiplier' ('MuLt') from 1 to 9999.
- assign the value for parameter 'Divider' ('dIV') from 1 to 9999.
- select the value for the 'Time window' ('GAtE'). Available values are : 0.5, 1.0, 2.0, 4.0, 8.0 or 16.0 seconds. The time window defines the display refresh time. This parameter has no effect if the 'SLOW' mode is active.

1.19 Configuration menu (cont.)

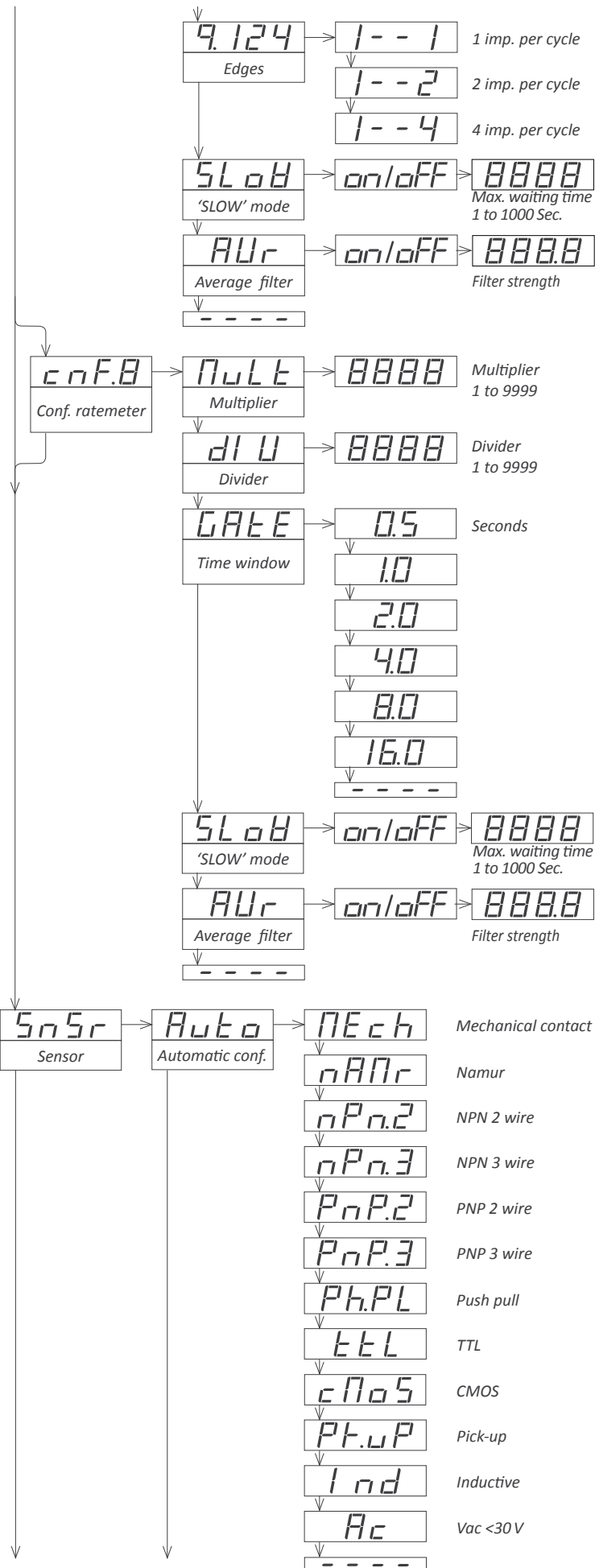

- select the 'edges' to count for each quadrature cycle ('q.124'). Select '1--1' for 1 impulse per quadrature cycle. Select '1--2' for 2 impulses per quadrature cycle. Select '1--4' for 4 impulses per quadrature cycle.

- for slow frequencies, activate the 'SLOW' mode and assign the 'Maximum waiting time' between 1 and 1000 seconds. See section 1.15 for more information on the 'SLOW' mode.

- in case of unstable signals, activate the 'average filter' ('AVR') function. It activates a recursive filter on the reading. the filter is stronger for higher values, from 0.0 to 99.9.

1.19.9 Configuration for 'Prd.8'

Configuration menu for mode 'periodmeter' ('Prd.8'). Period measured is multiplied by the value of the 'multiplier' ('MuLt') register and divided by the 'divider' ('diV') register. Result is refreshed on the display. Measure is updated at the rate defined on the 'GATE' register.

- assign the value for parameter 'Multiplier' ('MuLt') from 1 to 9999.

- assign the value for parameter 'Divider' ('diV') from 1 to 9999.

- select the value for the 'Time window' ('GATe'). Available values are : 0.5, 1.0, 2.0, 4.0, 8.0 or 16.0 seconds. The time window defines the display refresh time. This parameter has no effect if the 'SLOW' mode is active.

- for long periods, activate the 'SLOW' mode and assign the 'Maximum waiting time' between 1 and 1000 seconds. See section 1.15 for more information on the 'SLOW' mode.

- in case of unstable signals, activate the 'average filter' ('AVR') function. It activates a recursive filter on the reading. the filter is stronger for higher values, from 0.0 to 99.9.

1.19.10 Sensor configuration

The sensor configuration menu ('SnSr') provides configuration for the input section of the instrument, the excitation voltage and the trigger level, for accurate detection of the impulses.

- 'Automatic configuration' ('Auto') - if a standard sensor is used, select one of the sensors provided at the 'Auto' menu list. The instrument will automatically configure the parameters according to Table 2 (see section 1.8). If this configuration does not detect impulses, manually modify the values for the parameters indicated below.

1.19 Configuration menu (cont.)

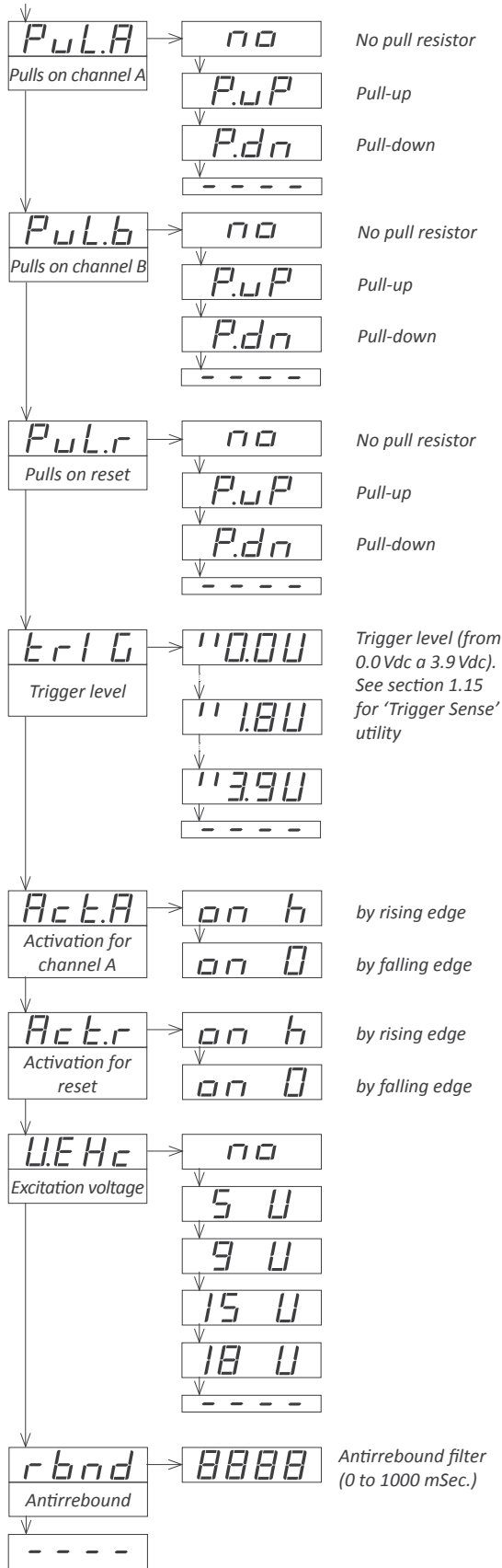

- **'Pulls on channel A' ('PuL.A')** - activates pull resistors at channel A. Select **'PuP'** to activate pull-up resistors (needed for NPN sensors). Select **'P.dn'** to activate pull-down resistors (needed for PNP sensors). Pull-up and pull-down selection configure the trigger level to 2,5 Vdc.

- **'Pulls on channel B' ('PuL.b')** - see previous menu entry 'Pulls on channel A'.

- **'Pulls on reset' ('PuL.r')** - see previous menu entry 'Pulls on channel A'. Trigger level for reset channel is fixed to 2,5 Vdc.

- **'trigger level' ('trIG')** - input signal value in Vdc at which the instrument detects impulse. Selectable between 0,0 and 3,9 Vdc. Trigger level is the same for channels A and B. Trigger level for reset channel is fixed at 2,5 Vdc. The two leds at the left of the trigger level are part of the 'Trigger Sense' utility for easy location of the proper trigger level (see section 1.13).

- **'Activation for channel A' ('Act.A')** - configures the activation of channel A by rising edge (**'on_h'**) or by falling edge (**'on_0'**)

- **'Activation for reset channel' ('Act.r')** - configures the activation of the reset channel by rising edge (**'on_h'**) or by falling edge (**'on_0'**)

- **'Excitation voltage' ('UEHc')** - configures the value of the excitation voltage at 5 Vdc, 9 Vdc, 15 Vdc and 18 Vdc. Select 'no' to disable the excitation voltage.

- **'Antirrebound filter' ('rbnd')** - the antirrebound filter blocks additional rebounds (typically from a mechanical contact sensor) from the same single impulse, preventing that a single impulse counts for more than 1. Value between 0 mSeconds and 1000 mSeconds. When an impulse is received, impulse detection is disabled for the duration of the time configured in this parameter. After time has passed, impulse detection is enabled again. Recommended value for a mechanical contact : 100 mSeconds.

1.19 Configuration menu (cont.)

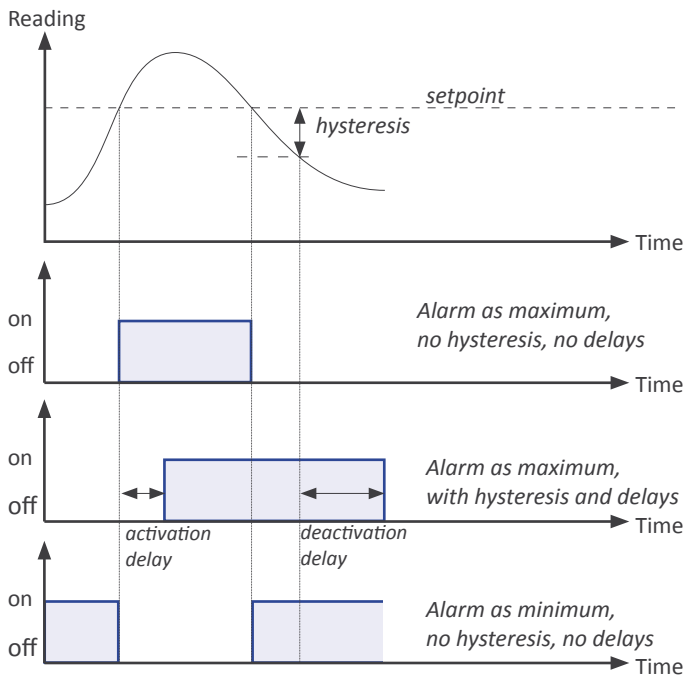
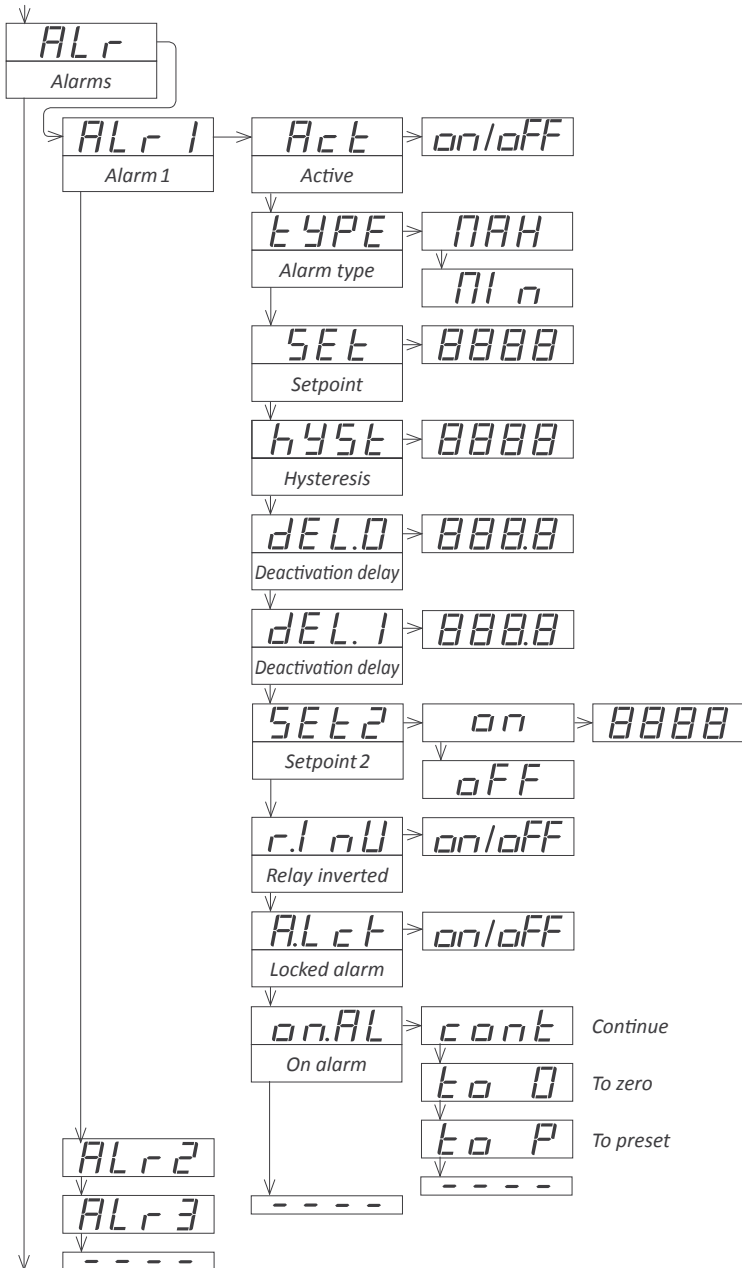

1.19.11 Alarms

The 'Alarms' ('ALr') menu configures the independent activation of up to 3 relay outputs, installed with the R1 optional modules (see section 2.1). For outputs up to 4 and 6 relays, see special modules R2, R4 and R6 at section 2.6. The alarm states are indicated in the front display with leds marked as '1', '2' and '3'.

To configure an alarm, enter into the alarm menu ('ALr1', 'ALr2' or 'ALr3') and configure the following parameters :

- select 'Active' ('Act') to 'on'.
- at 'Alarm type' ('Type') select the alarm to act as a maximum type alarm ('MAX') or a minimum type alarm ('Min'). The maximum type alarm (or minimum type alarm) activates when the display value is higher (or lower) than the setpoint value.
- at 'Setpoint' ('Set') enter the value for the alarm activation point. This parameter is eligible for configuration through the 'Fast access' menu (see section 1.19.12).
- configure the hysteresis value at 'Hysteresis' ('hyst'). The hysteresis applies to the deactivation process of the alarm. The alarm deactivates when the reading has passed the setpoint value plus the hysteresis value. Hysteresis helps to avoid repetitive switching of the alarm relays, due to fluctuating input signals around the setpoint.
- at 'Activation delay' ('dEL.0') configure the delay to apply before alarm activation. The activation delay starts counting when the setpoint value is passed. Value from 0.0 to 99.9 seconds.
- at 'Deactivation delay' ('dEL.1') configure the delay to apply before alarm deactivation. The deactivation delay starts counting when the setpoint value plus the hysteresis value, is passed. Value from 0.0 to 99.9 seconds.
- to work with 'windowed alarms' (see graphical example below) activate 'Setpoint 2' ('Set2') to 'on' and then configure the desired second setpoint value. Second setpoint must always be higher in value than the first setpoint.
- the 'Relay inverted' ('r.Inv') parameter inverts the normal relay connections. When set to 'on' the relay will be active when alarm is inactive. For security applications where an inactive relay controls the shutdown of the system.
- the 'Locked alarm' ('A.Lck') parameter disables the automatic deactivation of the alarm. Alarm deactivation must be performed manually, by pressing the 'LE' front button (see section 1.19.15)
- the 'On alarm' ('on.AL') parameter assigns a predefined behaviour when alarm is activated. Select 'cont' to continue counting. Select 'to_0' to load '0' on displays. Select 'to_p' to load preset value on display. Parameter 'dEL.1' is set to 1 second when 'to_0' or 'to_p' are selected.

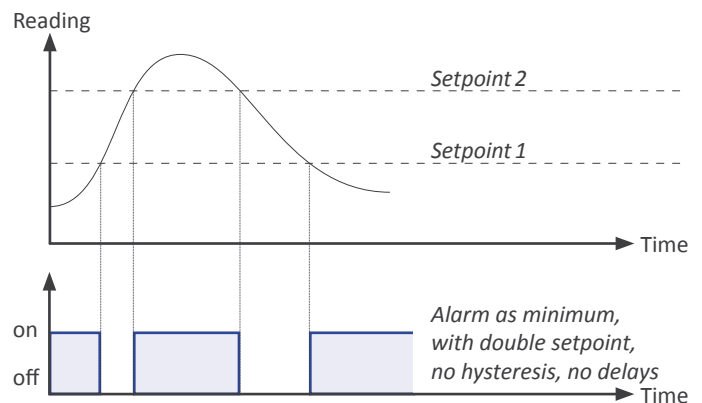

1.19 Configuration menu (cont.)

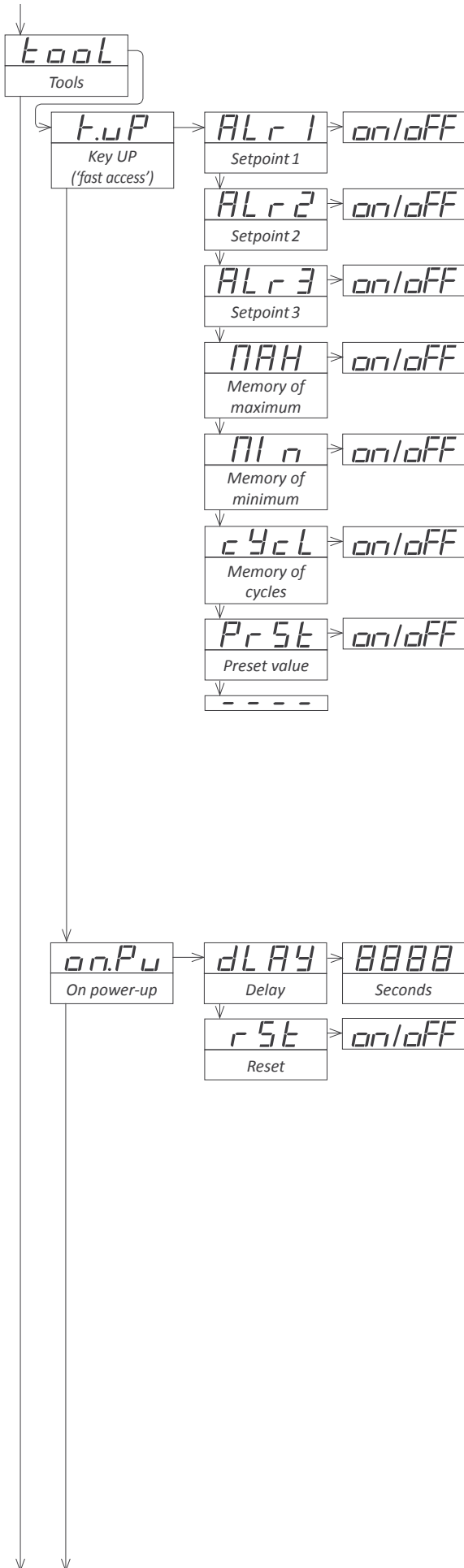

1.19.12 Fast access

The 'UP' (▲) key at the front of the instrument gives access to a list of functions configurable by the operator. See section 1.17 for an explanation on how to operate the 'fast access' menu.

The 'Key UP (Fast access)' ('K.uP') menu allows to select which functions will be accessible through the 'fast access' menu. Select 'on' to activate each function.

- the 'Setpoint 1' ('ALr1') function allows to visualize and modify the alarm 1 setpoint through the 'fast access' menu.
- the 'Setpoint 2' ('ALr2') function allows to visualize and modify the alarm 2 setpoint through the 'fast access' menu.
- the 'Setpoint 3' ('ALr3') function allows to visualize and modify the alarm 3 setpoint through the 'fast access' menu.
- the 'Memory of maximum' ('MAX') or 'Memory of minimum' ('MIn') functions allow to visualize the maximum or minimum reading value stored in memory. To reset this value, visualize the memory value at the 'fast access' menu with key UP (▲) and when message 'rSt' is displayed, press (■) to reset.
- the 'Memory of cycles' ('cYcL') function allow to visualize and reset the memory of cycles. To reset this value, visualize the memory value at the 'fast access' menu with key UP (▲) and when message 'rSt' is displayed, press (■) to reset. The memory of cycles counts '+1' each time a reset alarm occurs ('on_AL' / 'to_0' or 'to_P') or a reset by 'overrange' / 'underrange' occurs.
- the 'Preset value' ('PrSt') function allows to visualize and modify the preset value configured.

1.19.13 Super fast access

If only a single function is selected for the 'fast access' menu, pressing the the 'UP' (▲) key will shortly display the function name and then automatically jump to the function value.

1.19.14 Menu 'On Power Up'

The 'On Power Up' ('on.Pu') menu configures functions to apply at start-up. It applies only to instrument restart after power loss. It does not apply to instrument restart due to change in configuration.

- parameter 'Delay' ('dLAY') assigns a waiting time in seconds. The instrument waits the configured time before starting normal function. During this waiting time, the display shows all decimal points on in flash mode, all alarms are in 'oFF' state, there is no signal acquisition and there is no communications or control being performed. After the configured time is over, the instrument starts in normal function.

Application - the start-up process for an automation system implies that different parts of the system (engines, actuators, controllers, ...) have different start-up times. The 'Delay' function gives time to the instrument to wait until the slowest part of the system is fully functional before executing actions on the system (signal reading, relay activation, ...)

- the 'Reset' ('rSt') parameter will execute a reset of the counter each time the instrument is restarted.

1.19 Configuration menu (cont.)

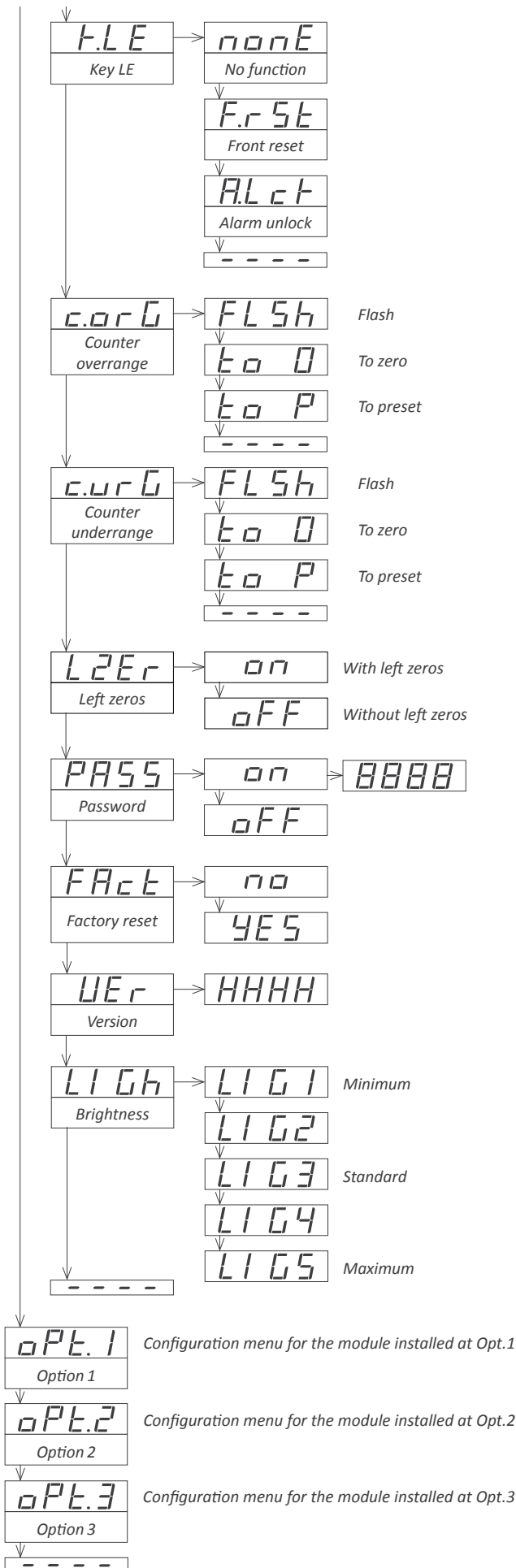

1.19.15 Menu 'Key LE'

The 'LE' (◀) key at the front of the instrument can be configured to activate several functions. Only one function can be assigned to the 'LE' (◀) key

- the 'No function' ('nonE') value assigns no function.
- the 'Front reset' ('F.rSt') value assigns the reset function.
- the 'Alarm unlock' ('A.Lck') value assigns the manual unlock of the alarms function, for instruments with the 'Locked alarms' ('A.Lck') function activated (see section 1.19.11)

1.19.16 Menus 'Overrange / underrange'

The 'Counter overrange' ('c.orG') and 'Counter underrange' ('c.urG') parameters configure the behavior of the instrument when reading is higher than '9999' (overrange) or lower than '-1999' (underrange). Select 'FLSH' to enter reading into flash mode. Select 'to_0' to apply a reset to '0'. Select 'to_P' to apply a reset to preset value.

1.19.17 Left zeros

The 'Left zeros' ('L.ZEr') parameter controls the left zeros on or off.

1.19.18 Function 'Password'

At the 'Password' ('PASS') menu select a 4 digit code to block access to the 'configuration menu'. Instrument configuration will not be accessible to non authorized personnel. To activate the 'Password' select 'on' and introduce the code.

The code will be requested when trying to access the 'configuration menu' (key 'SQ' (■)). The 'fast access' menu is not password protected.

1.19.19 Factory reset

At the 'Factory reset' ('FAct') menu, select 'yes' to load the default factory configuration for the instrument (see section 1.21).

1.19.20 Firmware version

The 'Version' ('VEr') menu informs of the current firmware version installed in the module.

1.19.21 Brightness

At the 'Brightness' ('LIGh') menu select the light intensity for the front leds. With this function it is possible to adapt the instrument to the environment light intensity.

1.19.22 Access to optional modules

Menus 'Opt.1', 'Opt.2' and 'Opt.3' give access to the 'configuration menus' of the output and control modules installed at slots Opt.1, Opt.2 and Opt.3.

See section 2 for a list of output and control modules available for each slot. The 'configuration menu' of each module is described at the User's Manual of each module.

1.20 Full configuration menu

Press 'SQ' (■) for 1 second to access the 'Configuration menu'. See section 1.19 for a description of each menu entry.

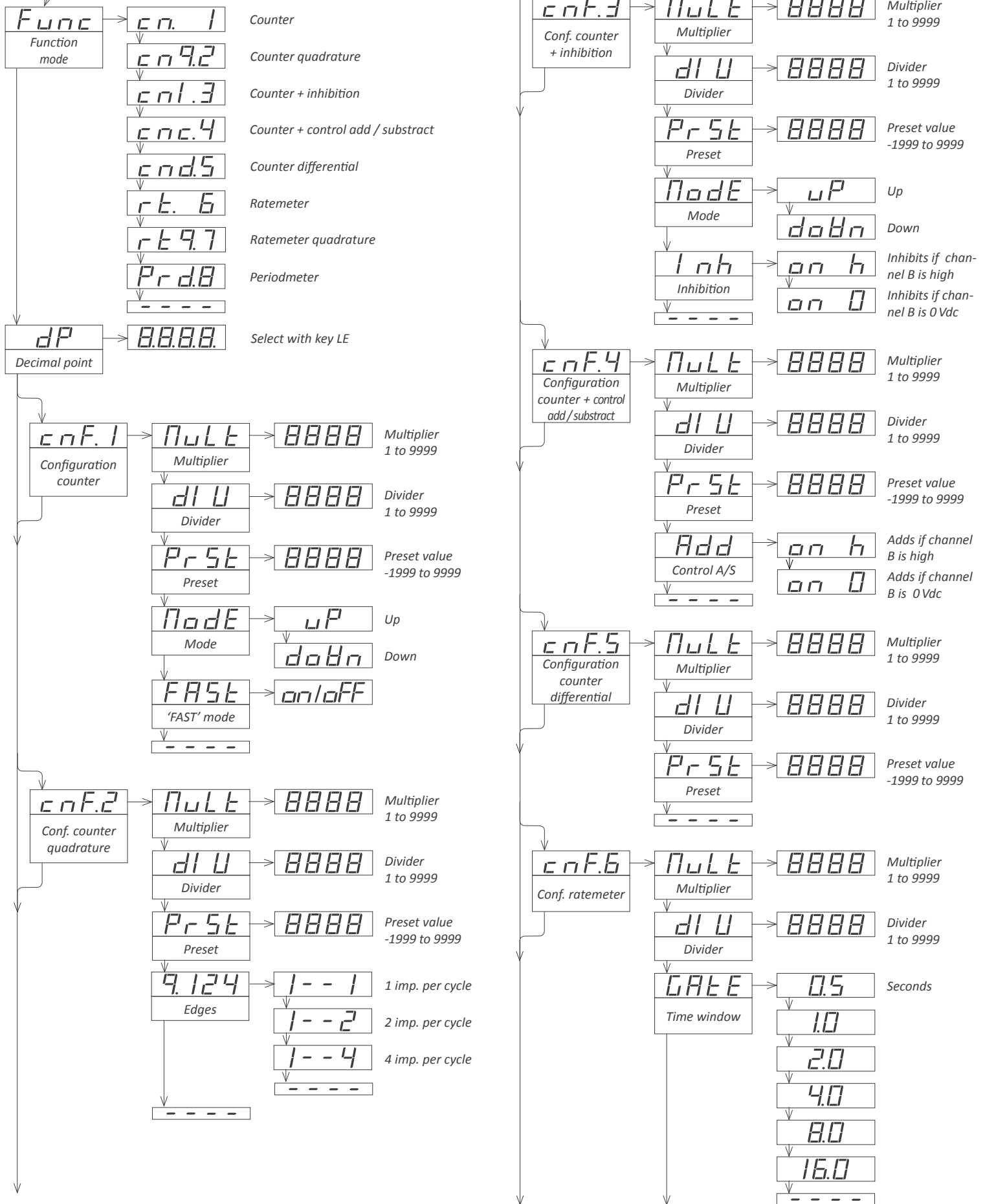

1.20 Full configuration menu (cont.)

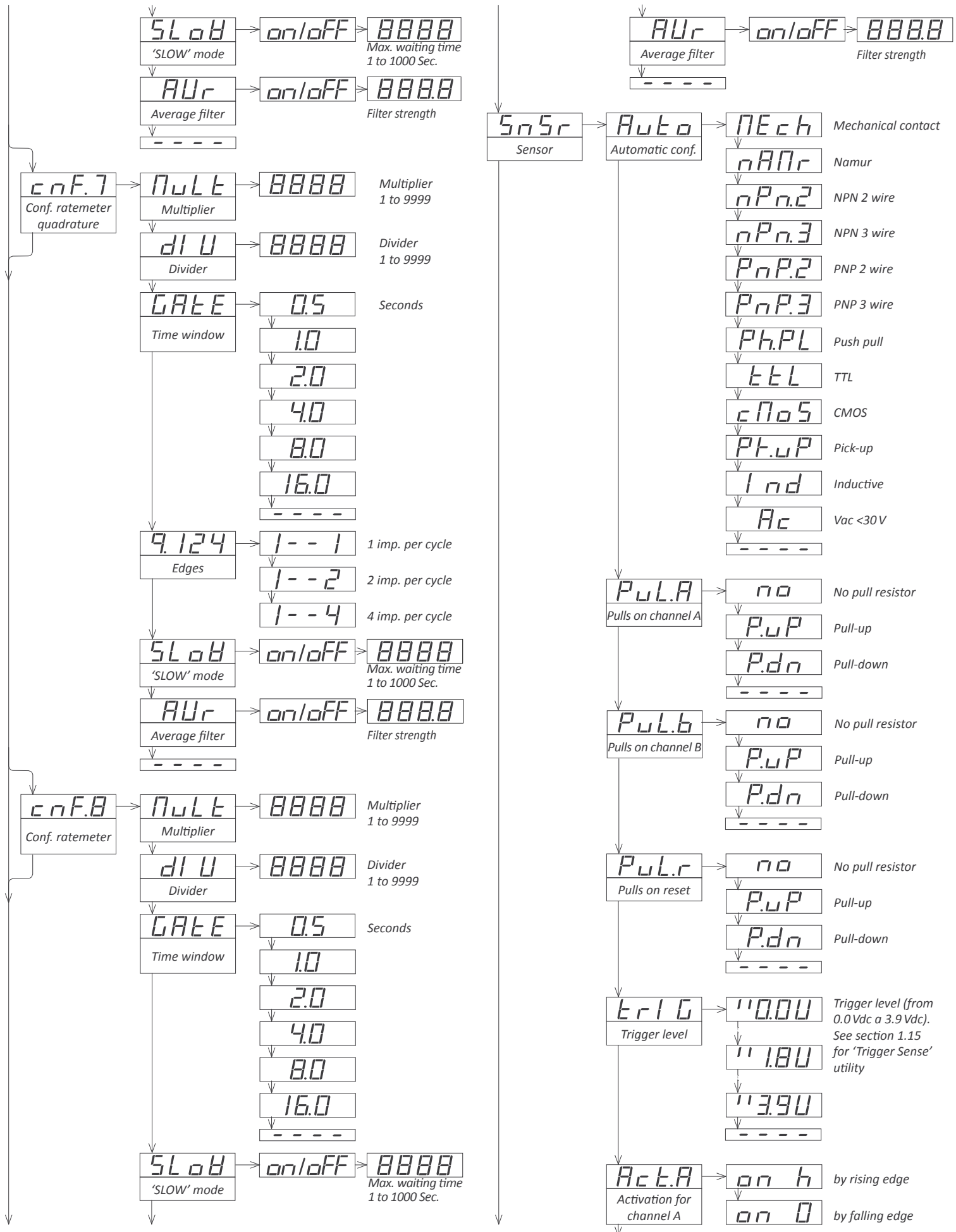

1.20 Full configuration menu (cont.)

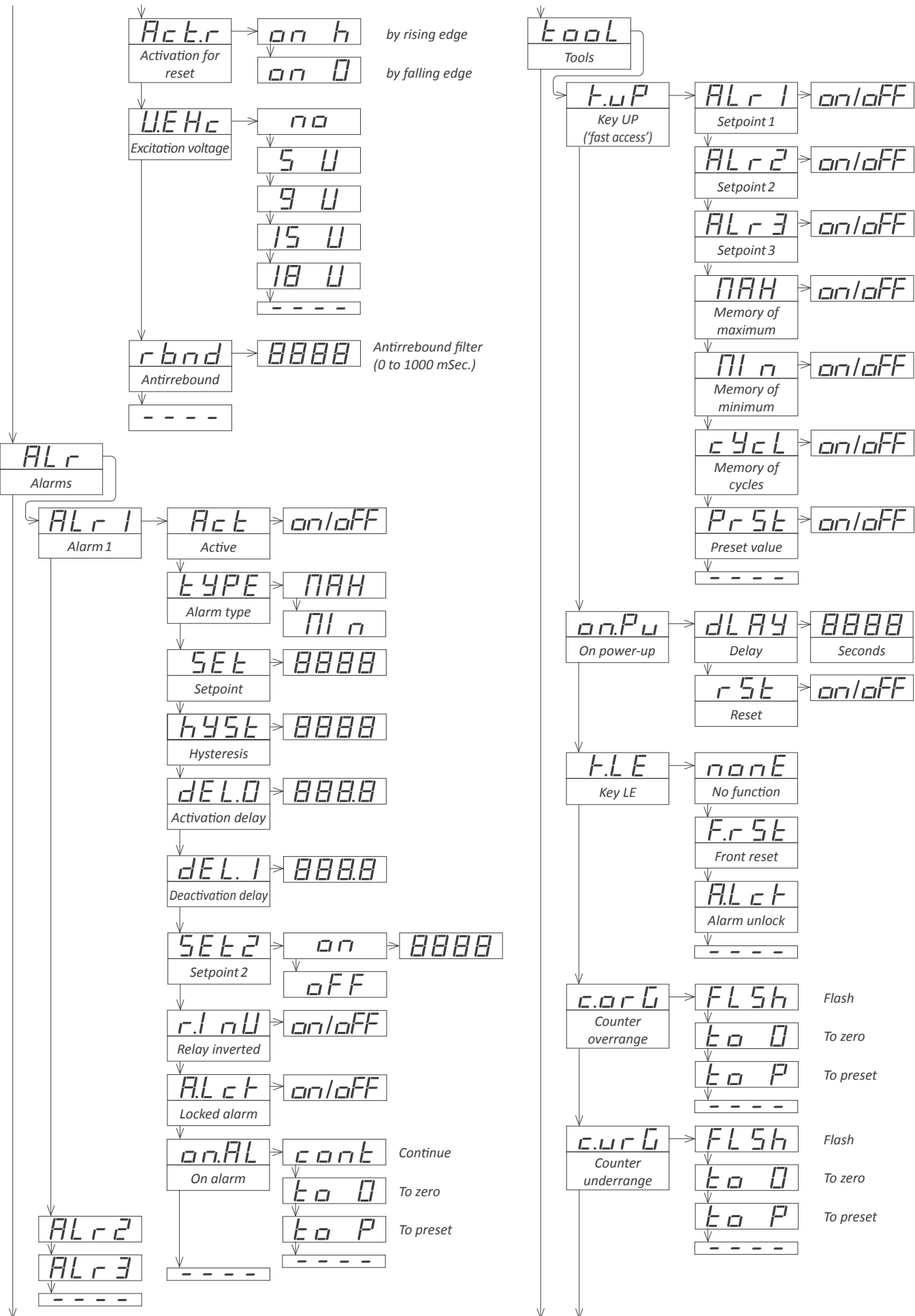

1.20 Full configuration menu (cont.)

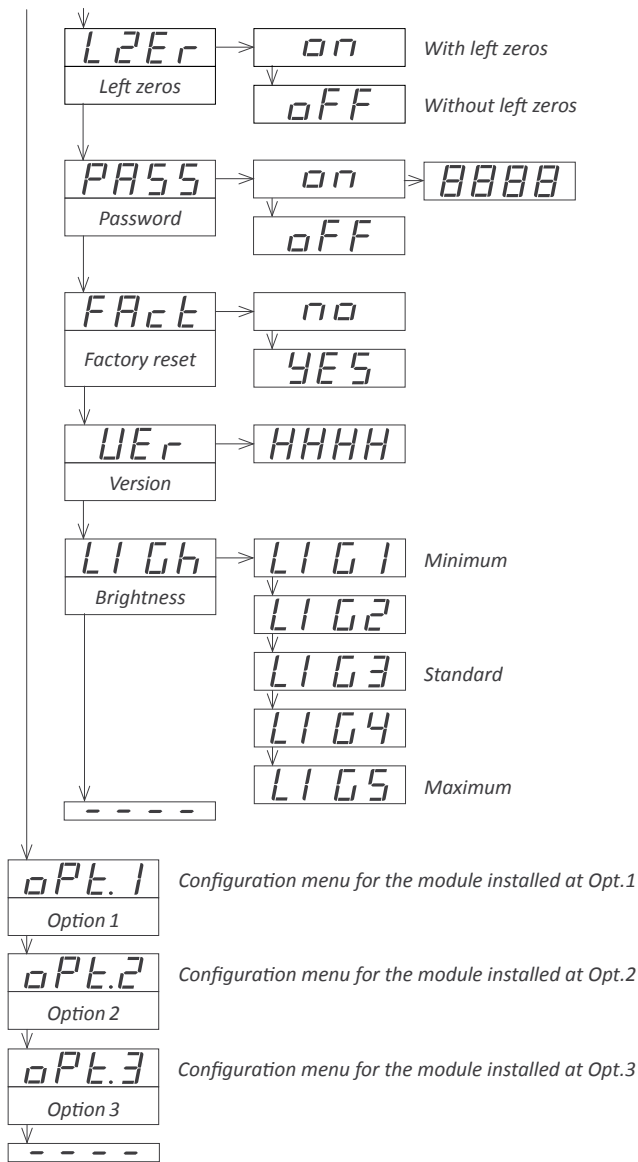

1.21 Factory configuration

Function	counter ('cn.1')
Decimal point	no
Counter configuration	
Multiplier	x1
Divider	/1
Preset	0
Mode	up
'FAST'	off
Sensor	
Pulls on channel A	no pull resistor
Pulls on channel B	no pull resistor
Pulls on reset	pull-up
Trigger	2,5 Vdc
Activation for channel A	on rising edge ('on_h')
Excitation voltage	5 Vdc
Antirrebound filter	0 mSeconds
Tools	
Fast access (Key UP)	off
'On Power Up'	
Delay	0 seconds
Key 'LE'	reset function
Memory of maximum	-1999
Memory of minimum	9999
Memory of cycles	0
Counter overrange	flash
Counter underrange	flash
Left zeros	off
Password	off
Brightness	3
Alarms 1,2 and 3	
Active	off (disabled)
Type	maximum
Setpoint	1000
Hysteresis	0 counts
Activation delay	0.0 seconds
Deactivation delay	0.0 seconds
Setpoint 2	off
On Alarm	continue
Inverted relay	off
Locked alarms	off

Factory configuration for Ratemeter ('cnF.6) and periodmeter ('cnF.8) modes.

Multiplier	x1
Divider	/1
Time windows	0.5
'SLOW' mode	off
Recursive filter	off

1.22 To access the instrument

You may need to access the inside of the instrument to add or replace internal modules. Use a flat screwdriver to unlock the upper clips marked with 'A'. Then unlock the lower clips marked with 'B' and remove the front cover. Let the inside of the instrument slide out of the housing.

To reinsert the instrument make sure that all modules are correctly connected to the pins on the display module. Place all the set into the housing, assuring that the modules correctly fit into the internal guiding slides of the housing. Once introduced, place again the front cover by clipping first the upper clips 'A' and then the lower clips 'B'.

Important - If your instrument was delivered with the IP65 front seal option, accessing the inside of the instrument will permanently break the IP65 seal on the areas of clips 'A' and 'B'.

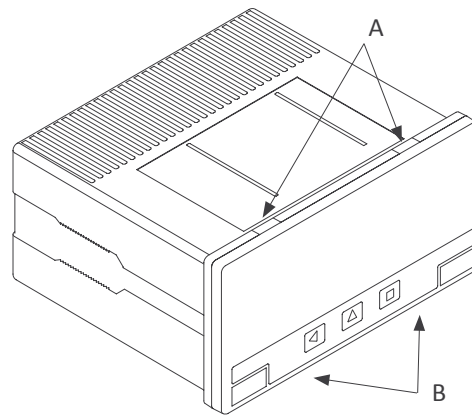

Risk of electric shock. Removing the front cover will grant access to the internal circuits. Disconnect the input signal to prevent electric shock to the operator. Operation must be performed by qualified personnel only.

1.23 Modular system

K Series panel meters are designed to create a modular system. This modular system allows for addition, replacement or substitution of any of the internal modules conforming the instrument. Below is a graphic explanation for the position of each module.

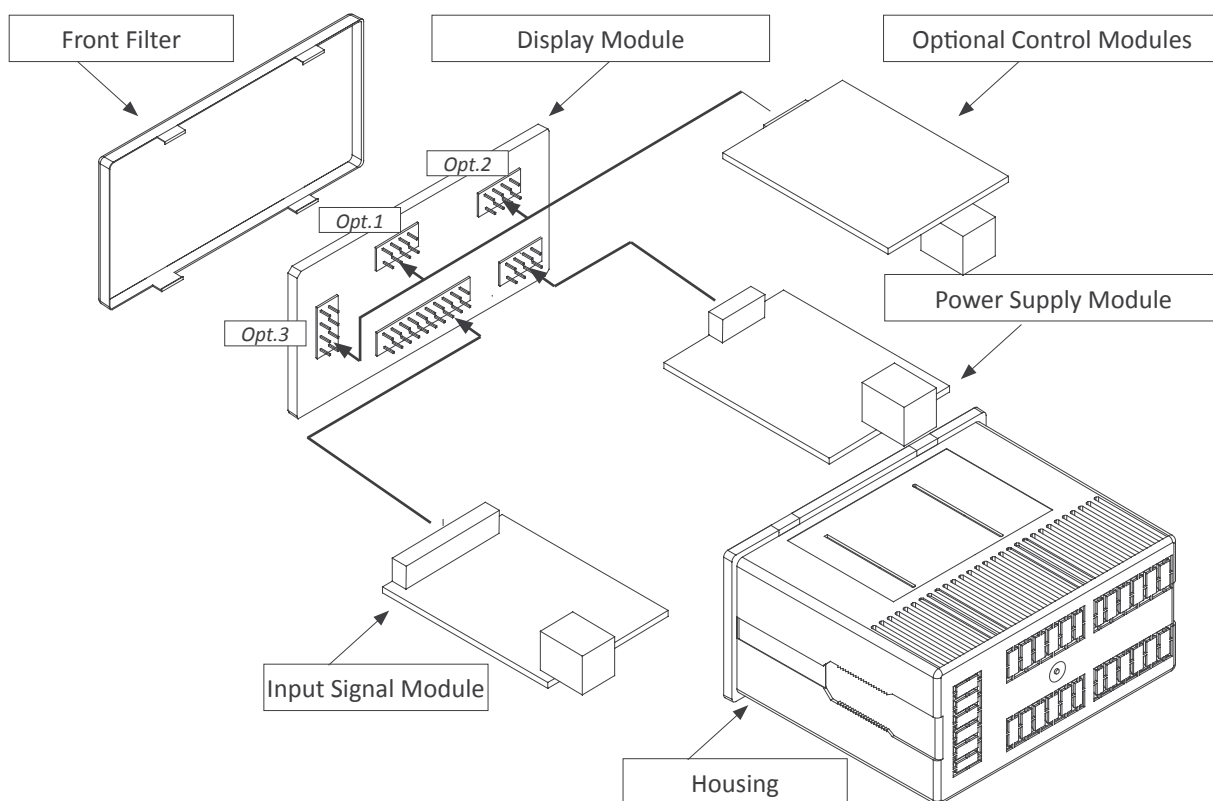

1.24 Precautions on installation



Risk of electrical shock. Instrument terminals can be connected to dangerous voltage.



Instrument protected with double isolation. No earth connection required.



Instrument conforms to CE rules and regulations.

This instrument has been designed and verified conforming to the 61010-1 CE Security Regulation, for industrial applications.

Installation of this instrument must be performed by qualified personnel only. This manual contains the appropriate information for the installation. Using the instrument in ways not specified by the manufacturer may lead to a reduction of the specified protection level. Disconnect the instrument from power before starting any maintenance and / or installation action.

The instrument does not have a general switch and will start operation as

soon as power is connected. The instrument does not have protection fuse, the fuse must be added during installation.

The instrument is designed to be panel mounted. An appropriate ventilation of the instrument must be assured. Do not expose the instrument to excess of humidity. Maintain clean by using a humid rag and do NOT use abrasive products such as alcohols, solvents, etc.

General recommendations for electrical installations apply, and for proper functionality we recommend : if possible, install the instrument far from electrical noise or magnetic field generators such as power relays, electrical motors, speed variators, ... If possible, do not install along the same conduits power cables (power, motor controllers, electrovalves, ...) together with signal and/or control cables.

Before proceeding to the power connection, verify that the voltage level available matches the power levels indicated in the label on the instrument.

In case of fire, disconnect the instrument from the power line, fire alarm according to local rules, disconnect the air conditioning, attack fire with carbonic snow, never with water.

1.25 Warranty

This instrument is warranted against all manufacturing defects for a period of 24 MONTHS from the shipment date. This warranty does not apply in case of misuse, accident or manipulation by non-authorized personnel. In case of malfunction get in contact with your local provider to arrange for repair. Within the warranty period and after examination by the manufacturer, the unit will be repaired or substituted when found to be defective. The scope of this warranty is limited to the repair cost of the instrument, not being the manufacturer eligible for responsibility on additional damages or costs.

1.26 CE declaration of conformity

Manufacturer FEMA ELECTRÓNICA, S.A.
Altimira 14 - Pol. Ind. Santiga
E08210 - Barberà del Vallès
BARCELONA - SPAIN
www.fema.es - info@fema.es

Products K40-C1

The manufacturer declares that the instruments indicated comply with the directives and rules indicated below.

Directive of electromagnetic compatibility 2004/108/CEE
Directive of low voltage 73/23/CEE

Security rules 61010-1

Instrument	Fixed Permanently connected
Pollution degree	1 and 2 (without condensation)
Isolation	Double

Emission rules

61000-6-4	Generic rules of emission
-----------	---------------------------

Immunity rules

61000-6-2	Generic rules of immunity
61000-4-2	By contact ± 4 KV - Criteria B By air ± 8 KV - Criteria B
61000-4-3	Criteria A
61000-4-4	On AC power lines : ± 2 KV - Criteria B On DC power lines : ± 2 KV - Criteria B On signal lines : ± 1 KV - Criteria B
61000-4-5	Between AC lines ± 1 KV - Criteria B Between DC lines ± 0.5 KV - Criteria B
61000-4-6	Criteria A
61000-4-8	30 A/m a 50 Hz - Criteria A
61000-4-11	0% 1 cycle - Criteria A 40% 10 cycles - Criteria A 70% 25 cycles - Criteria B 0% 250 cycles - Criteria B

Barberà del Vallès May 2014
Daniel Juncà - Quality Manager

2. Output and control modules

2.1 Module R1

The R1 module provides 1 relay output to K Series panel meters. Up to a maximum of 3 R1 modules can be installed in a single instrument (3 relays).

Note : for more than three relays per instrument or larger relay density per module, see special modules R2, R4 and R6 at section 2.6.

Relays with 3 contacts each (common, normally closed, normally open), with switching capability up to 250V @ 8A.

Modules R1 are configured from the 'ALr1', 'ALr2' and 'ALr3' alarm menus of the panel meter. The 'ALrX' menus provide configuration for main setpoint, hysteresis, independent activation and deactivation delays, and a second setpoint to create windowed alarms.

Modules R1 are installed on slot 'Opt.1', 'Opt.2' or 'Opt.3' (see section 1.23) and are configured from instruments front keypad.

The R1 module can be ordered pre-installed into a K Series panel meter, or standalone for delayed installation, as they do not require soldering or special configuration.

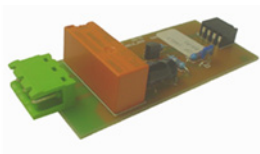

Type of relay	3 contact relay (NC, NO, common)
Current maximum	8A per relay (resistive load)
Voltage maximum*	250 Vac continuous
Type of terminal	plug-in screw terminal, pitch 5.08 mm
Slots allowed	'Opt.1', 'Opt.2', 'Opt.3' (see section 1.23)

2.2 Module AO

The AO module provides 1 analog output with 4/20 mA or 0/10 Vdc configurable output range. Output current loop configurable as active (the instrument provides the excitation for the loop) or passive (the loop is externally powered). Signal output proportional to the instruments reading. Fully configurable scaling, in direct (positive slope) or inverse (negative slope) scaling.

Up to a maximum of 3 analog output modules can be installed in a single instrument, all outputs isolated between them and isolated from the power and input signal circuits.

Configuration from instrument front keypad, through menu entries 'Opt.1', 'Opt.2' or 'Opt.3', depending on the position the module is installed (see section 1.23).

The RTU module can be ordered pre-installed into a K Series panel meter, or standalone for delayed installation, as it does not require soldering or special configuration.



Output ranges	4/20 mA active, 4/20 mA passive 0/10 Vdc
Accuracy (at 25 °C)	<0.1% FS
Isolation	1000 Vdc
Slots allowed	'Opt.1', 'Opt.2', 'Opt.3' (see section 1.23)

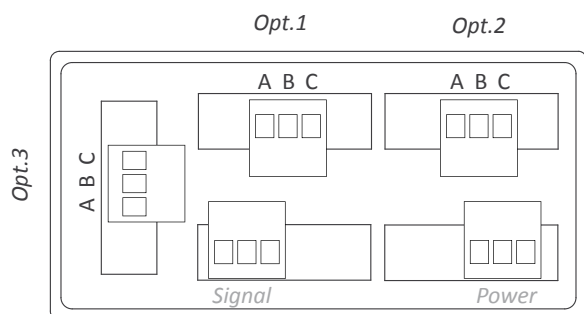

Terminal A	Common
Terminal B	NO - Normally Open
Terminal C	NC - Normally Closed

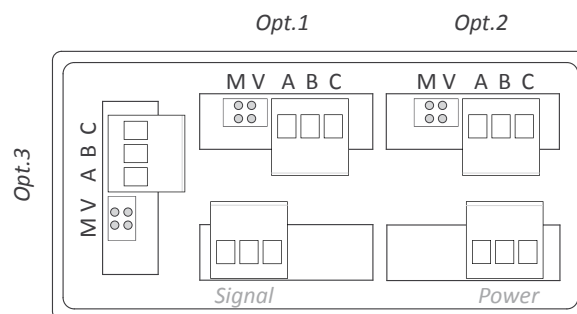

Terminal A	Vexc
Terminal B	Signal in mA or Vdc
Terminal C	GND
Jumper M	closed for mA
Jumper V	closed for Vdc

For more information see document 3543_SERIES-K_MODULE-R1_i.pdf

For more information see document 3541_SERIES-K_MODULE-AO_i.pdf

2.3 Module RTU

The RTU module provides a Modbus RTU communications module for K Series of panel meters. The RTU module implements function '4' ('Read Input Registers') of the Modbus RTU protocol, to access the instrument registers (reading value, alarm status, memory of maximum and minimum, ...)

Configuration from instrument front keypad, through menu entries 'Opt.1', 'Opt.2' or 'Opt.3', depending on the position the module is installed (see section 1.23).

The RTU module can be ordered pre-installed into a K Series panel meter, or standalone for delayed installation, as it does not require soldering or special configuration.



Protocol	Modbus RTU
Functions implemented	4 (Read_Input_Registers)
Bus type	RS-485, up to 57.6 Kbps
Isolation	1000Vdc
Slots allowed	'Opt.1', 'Opt.2', 'Opt.3' (see section 1.23)

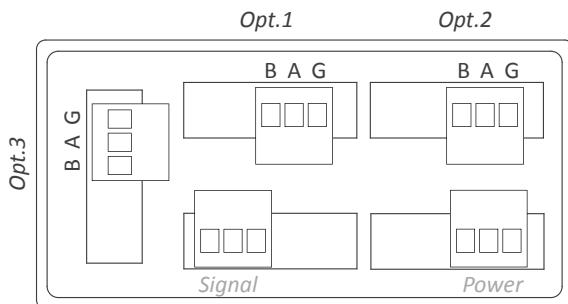

Terminal B B signal from RS-485 bus
 Terminal A A signal from RS-485 bus
 Terminal G GND

For more information see document 3545_SERIES-K_MODULE-RTU_i.pdf

2.4 Module S4

The S4 module provides a RS-485 communications module for K Series of panel meters. ASCII protocol with 'Master' / 'Slave' architecture. Addressable with up to 31 modules. Frames codified in representable ASCII characters (codes 32 to 255), directly visible using 'hyperterminal' or similar programs.

- Configurable for direct retransmission to remote meter of K Series (20mm digit height) and BDF Series (60mm and 100mm digit height).

- Access to display values, alarm status, memory of maximum and minimum, alarm setpoints, ...

Configuration from instrument front keypad, through menu entries 'Opt.1', 'Opt.2' or 'Opt.3', depending on the position the module is installed (see section 1.23).

The S4 module can be ordered pre-installed into a K Series panel meter, or standalone for delayed installation, as it does not require soldering or special configuration.



Protocol	ASCII
Bus type	RS-485, up to 57.6 Kbps
Isolation	1000Vdc
Slots allowed	'Opt.1', 'Opt.2', 'Opt.3' (see section 1.23)

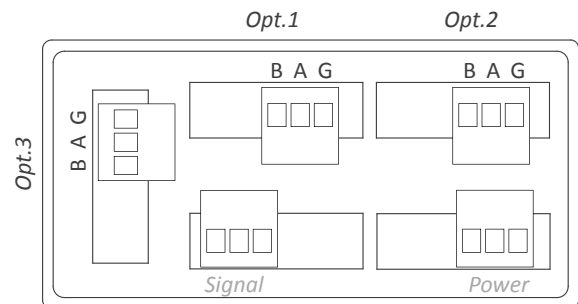

Terminal B B signal from RS-485 bus
 Terminal A A signal from RS-485 bus
 Terminal G GND

For more information see document 3547_SERIES-K_MODULE-S4_i.pdf

2.5 Module S2

The S2 module provides a RS-232 communications module for K Series of panel meters. ASCII protocol with 'Master' / 'Slave' architecture. Addressable with up to 31 modules. Frames codified in representable ASCII characters (codes 32 to 255), directly visible using 'hyperterminal' or similar programs.

- Access to display values, alarm status, memory of maximum and minimum, alarm setpoints, ...

Configuration from instrument front keypad, through menu entries 'Opt.1', 'Opt.2' or 'Opt.3', depending on the position the module is installed (see section 1.23).

The S2 module can be ordered pre-installed into a K Series panel meter, or standalone for delayed installation, as it does not require soldering or special configuration.



Protocol	ASCII
Bus type	RS-232, up to 57.6 Kbps
Isolation	1000 Vdc
Slots allowed	'Opt.1', 'Opt.2', 'Opt.3' (see section 1.23)

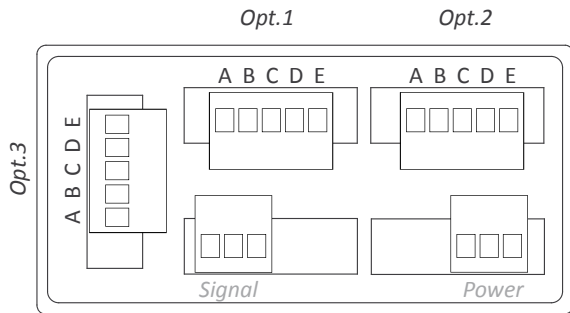

Terminal A	GND
Terminal B	Rx1
Terminal C	Tx1
Terminal D	Rx2
Terminal E	Tx2

2.6 Modules R2, R4, R6

The R2, R4 and R6 modules provide 2, 4 and 6 relay outputs for K Series panel meters. Relays with 3 contacts each, with switching capability up to 250 V @ 6 A.

Modules R2, R4 and R6 are installed on slot 'Opt.1' (see section 1.23) and are configured from instruments front keypad, and provide set-point configuration, hysteresis, independent activation and deactivation delays, and second alarm setpoint for windowed alarms.

Only one module R2, R4 or R6 can be installed per instrument. Modules R2, R4 and R6 are not compatible with standard R1 modules.

The R2, R4 and R6 modules can be ordered pre-installed into a K Series panel meter, or standalone for delayed installation, as they do not require soldering or special configuration.



Type of relay	3 contact relay (NC, NO, common)
Current maximum	6 A per relay (resistive load)
Voltage maximum*	250 Vac continuous
Type of terminal	plug-in screw terminal, pitch 3.81 mm
* terminals approved for 300 V (according to UL1059, groups B and D) and 160 V (according to VDE on CAT-III and pollution degree 3).	
Module R2	occupies Opt.1
Module R4	occupies Opt.1 and Opt.2
Module R6	occupies Opt.1, Opt.2 and Opt.3

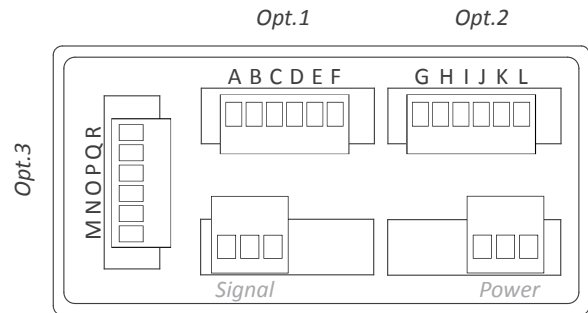

Relay	Common	Normally Open (NO)	Normally Closed (NC)
relay 1	A	B	C
relay 2	D	E	F
relay 3	G	H	I
relay 4	J	K	L
relay 5	M	N	O
relay 6	P	Q	R

Table 7 - Connections for modules R2, R4 and R6

For more information see document 3549_SERIES-K_MODULE-S2_i.pdf

For more information see document 3551_SERIES-K_MODULES-R2-R4-R6_i.pdf

This page blank

3. Other options

3.1 Option NBT

Instruments without front keypad. To configure the instrument, remove the meter from the panel and remove the front filter. Internal press buttons for configuration are accessible. Optionally, request the instrument preconfigured from factory.



3.2 Option IP65

Front IP65 protection, with sealing of front filter clips.

* opening the front filter removes the IP65 sealing permanently.



4. Accessories

4.1 THM benchtop housing

Benchtop housing for M Series and K Series panel meters. Handle with three selectable positions. Power connector with manual switch and fuse holder.



4.3 Adapter DRA-M

Adapter for DIN rail mount, for M Series and K Series panel meters.



4.2 Adapter KA96

Adapter 96x96 mm for 96x48 mm instruments.



4.4 Protector IP65

Front IP65 protector, for M Series and K Series panel meters.





Panel meters
Standard 96x48 mm



Panel meters
Miniature 48x24 mm



Signal converters



Panel meters
Compact 72x36 mm



Large format meters



Bar meters



Isolators



Low cost



'Customized'
instruments

FEMA

ELECTRÓNICA

FEMA ELECTRÓNICA, S.A.

Altimira 14 - Pol. Ind. Santiga
E08210 Barberà del Vallès
BARCELONA - SPAIN

■ Tel. +34 93.729.6004
Fax +34 93.729.6003

■ info@fema.es
www.fema.es

