

Rely on us.



- System state acquisition
- Monitoring unit
- Remote control and maintenance
- Universal process I/O
- Open communication
- Energy management
- Data display
- Monitoring operating resources
- Data recording
- Power quality analysis



APLUS

The system for
heavy-current analysis



One device series – A variety of functions

The *APLUS* is a powerful platform for measuring, monitoring and analyzing power systems. The focus is on highest Swiss quality and maximum customer benefit.

This universal measurement device is available in three major versions: With TFT or LED display or in top hat-rail version without display. It can be easily integrated into the process environment on site. It provides a wide functionality, which may be further extended by means of optional components.

The connection of the process environment may be performed by means of the communication interface, via digital I/Os or via analog outputs.

Application

The *APLUS* is designed for applications in power distribution, in strongly distorted industrial environments and in building automation. Nominal voltages up to 690 V can directly be connected.

The *APLUS* is the ideal device for demanding measurement tasks where fast, accurate and insensitive analysis of power systems or loads is required. In addition it can also replace fault or limit monitoring devices, small control systems and summation stations of energy management systems.

Monitoring unit

- Universal analysis of limit values
- Combination of limit values
- Analysis of internal / external states

System state acquisition

- High updating rate
- Precise and uninterrupted
- For any power systems

Remote control and maintenance

- Remote I/O
- Remote data acquisition and parameterization
- Changeover local/remote operation

Universal process I/O

- State, pulse and synchronization inputs
- State and pulse outputs
- Relay outputs
- Analog outputs ± 20 mA

Energy management

- Active and reactive meters
- Load profiles, load curves
- Trend analysis
- Variance of system load
- Connection of external meters

Monitoring operating resources

- Operating times
- Service intervals
- Durations of overload situations
- Operation feedbacks

Power quality analysis

- Harmonic analysis
- Extended reactive power analysis
- Variance of short/long term load
- Power system imbalance
- Nominal condition monitoring

Long-term data storage

- Measurement progressions
- Disturbance information
- Events/alarms/system events
- Automatic meter readings

Open communication

- Free definable process image
- Modbus/RTU via RS485
- Modbus/TCP via Ethernet
- Profibus DP up to 12 Mbaud

Data display

- Measurements and meters
- Limit states
- Plain text alarming
- Alarm acknowledge and reset
- Free configurable display



The measurement system

The *APLUS* can be adapted fast and easily to the measurement task by means of the *CB-Manager* software. The universal measurement system of the device may be used directly for any system, from single phase up to 4-wire unbalanced networks, without hardware modifications. Independent of measurement task and outer influences always the same high performance is achieved.

The measurement is performed uninterrupted in all four quadrants and can be adapted to the system to monitor in an optimal way. The measurement time as well as the expected system load can be parameterized. The device can provide more than 1100 different measured quantities, which may be grouped as follows:

Measured quantities	Measurement uncertainty
Voltage, current	± 0.1%
Power, imbalance	± 0.2%
Harmonics, THD, TDD	± 0.5%
Frequency	± 0.01Hz
Load factors	± 0.1°
Active energy	Cl. 0.5S (EN 62 053-22)
Reactive energy	Cl. 2 (EN 62 053-23)

Overview of *APLUS* measurement uncertainty

Measurement group	Refreshing interval	Application
Instantaneous values	Configurable measurement interval (2...1024 cycles)	<ul style="list-style-type: none"> Monitoring present system state Unbalance monitoring Earth fault monitoring
Harmonic analysis	Approx. 2 times per second, depending on system frequency	<ul style="list-style-type: none"> Rating the thermal load of resources Analysis of system feedback and load structure
Extended reactive power analysis		<ul style="list-style-type: none"> Reactive power compensation
Voltage/current imbalance		<ul style="list-style-type: none"> Protection of operating resources Earth fault monitoring
Energy meters	Same as measurement interval	<ul style="list-style-type: none"> Billing purposes Energy efficiency monitoring Summation of external meter pulses
Power mean-values	Configurable, 1s...60 min	<ul style="list-style-type: none"> Load profiling for energy management
User-defined mean value quantities		<ul style="list-style-type: none"> Short-term fluctuations

Parameterization, service and measurement acquisition

The supplied **CB-Manager** software provides the following functions to the user:

- Complete parameterization of the *APLUS* (also offline)
- Acquisition and recording of measured quantities
- Archiving of configuration and measurement files
- Setting or resetting of meter contents
- Selective reset of extreme values
- Setting of interface parameters
- Simulation of logic module or outputs functions
- Comprehensive help system

A security system can be activated to restrict the access to device data. This way e.g. changing a limit value via display can be locked, but a setting via configuration could still be possible.

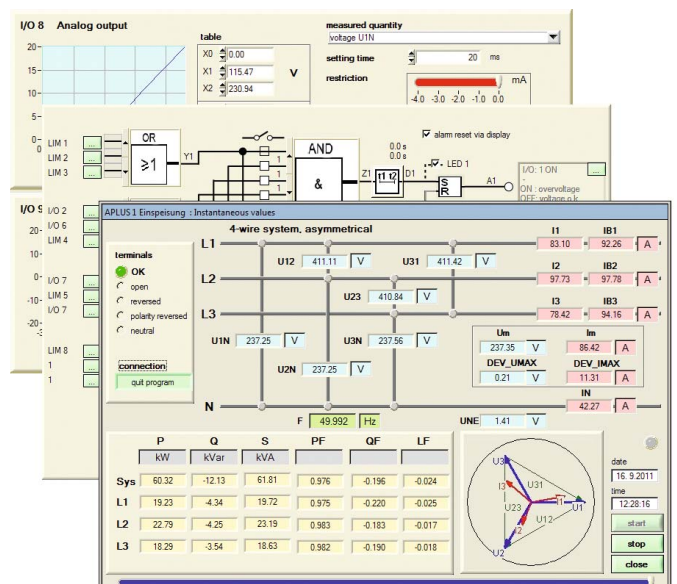

Energy management

The *APLUS* provides all functions needed to collect fast and efficient load data for an energy management system. A system composed of *APLUS* devices promises maximum accuracy and highest performance for each individual measurement point when used in power distributions. It can satisfy the following basic requirements:

- Recording load curves (Energy consumption over time)
- Acquisition of energy consumption summaries
- Automatic meter readings (calendric)
- Peak-load monitoring
- Trend analysis of present demand
- Load switch-off to prevent penalties

An energy optimization system can be composed of one device only and connecting already installed meters to it. The *APLUS* monitors then for example the main incoming supply and serves as well as a data summator station, which not only accumulates the contents of up to 7 meters of any kind of energy, but from the corresponding pulse rate can also derive their course in time – the load curve.

The collected energy data can also be recorded for years by means of the optional data logger. For the tabular or graphical analysis of these data the *CB-Analyzer* software is provided, which is in the scope of supply. This software collects data via Ethernet and stores them in a data base.

The sum of all these measures allows to achieve the following topics:

- Optimization of internal operating procedures
- Reduction of the total energy consumption
- Peak-load reduction

The cost savings achieved this way not only increases the profitability of the own company but also its competitiveness.

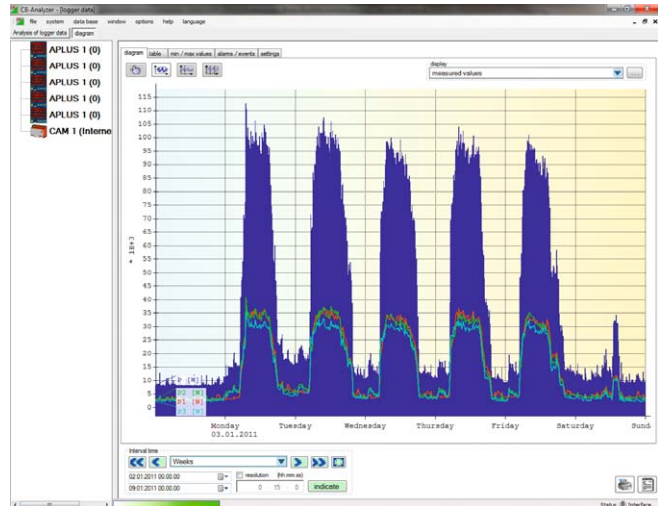

Load profile analysis using the *CB-Analyzer* software

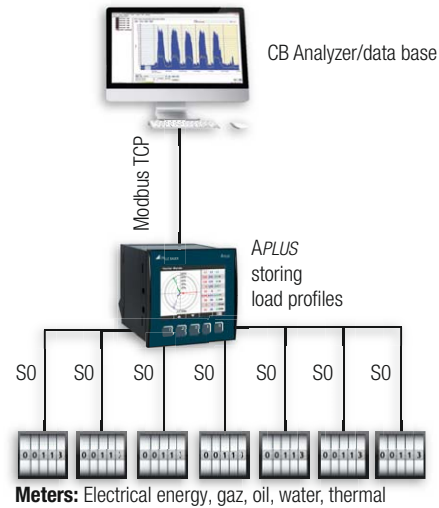

Example of a simple energy management system

Data analysis using the *CB-Analyzer*

The supplied *CB-Analyzer* software allows to read and analyze the data of the *APLUS* data logger. It provides the following functions to the user:

- Reading logger data (load curves, meter readings, min/max-courses, event lists, disturbance recordings)
- Data storage in a data base (Access, SQLClient)
- Graphical analysis of collected data
- Concurrent analysis of multiple devices
- Report generation in form of lists or graphics
- Selectable time range in report preparation
- Export of report data as Excel, PDF or WORD file

The *CB-Analyzer* software provides a comprehensive help functionality, which describes in detail the operation of the software.

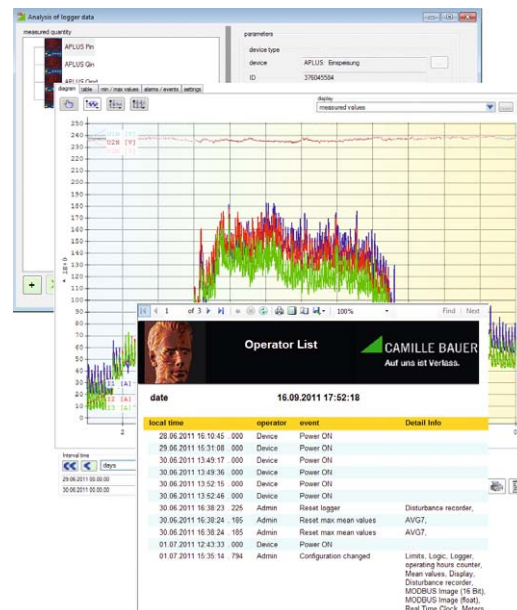

Power quality analysis instead of failure analysis

In the world of standards the quality of a grid is defined using statistical deviations from a desired standard behaviour. But what's really needed when monitoring power quality is a statement if the used operating resources will work undisturbed under the real existing conditions.

The *APLUS* therefore does not work with statistics, but examines the real environment, to allow performing a corresponding immunity analysis. Almost all important aspects of power quality can be investigated and interpreted.

Variation of the system load

The absolute minimum/maximum values with timestamp are available for instantaneous and mean values. They indicate the bandwidth of the variations of the system parameters.

Using the extreme value data logger also short-term variations within an interval can be acquired. This way e.g. a load profile can be recorded, where along with the mean power also the highest and lowest short-term demand will be shown.

System imbalance

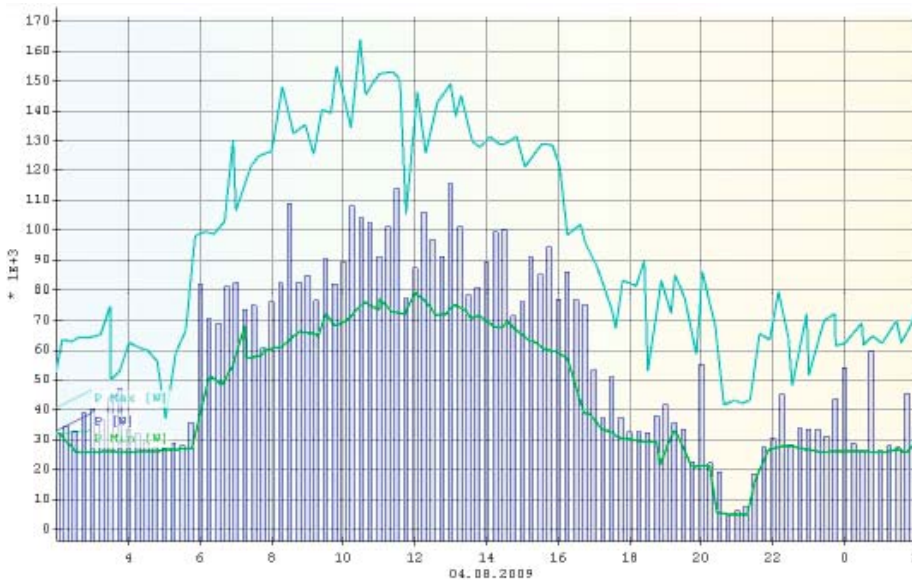

System imbalance not only occurs due to single phase load situations, but is often a sign for disturbances in the grid, such as isolation failure, phase failure or earth-leakage. Three phase loads are often very sensitive to operating voltages provided imbalanced. This may lead to a shorter lifetime or even damage.

An imbalance monitoring therefore not only helps to save costs in maintenance but also prolongs the undisturbed operating time of the used production facilities.

Additional load by harmonics

Harmonics originate from non-linear loads in the grid - a homemade pollution most of the time. They may induce an additional thermal stress to operational resources or cables and disturb the operation of sensitive loads.

The *APLUS* shows the harmonic contents of currents as Total Demand Distortion, briefly TDD. This value is scaled to the rated current resp. rated power. Only this way its influence on the connected equipment can be estimated correctly. In industrial grids the image of the harmonics often allows to determine quite good what types of loads are connected to the system.

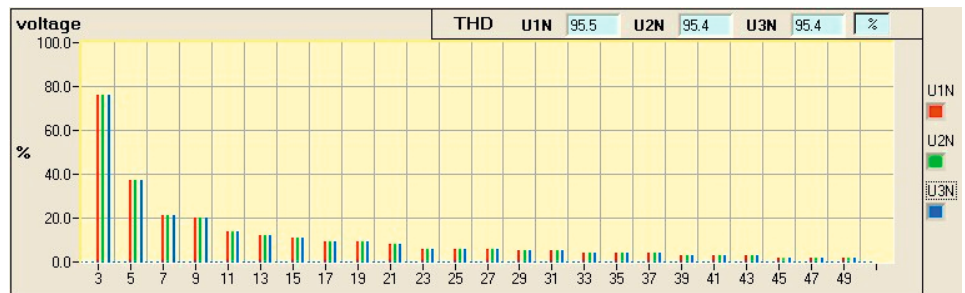

Hint: The accuracy of the harmonic analysis depends strongly on the quality of the current and voltage transformers possibly used, because harmonics are normally heavily distorted. It's valid: The higher the frequency of the harmonic, the higher its damping.

Violations of limit values

Important parameters, such as imbalance, should be checked continuously to protect important operating resources, by separating them from the grid in better time.

In association with the data logger violations of limit values may be recorded with the time of their occurrences.

Fundamental and distortion reactive power

The reactive power may be divided in a fundamental and a distortion component. Only the fundamental reactive power may be compensated using the classical capacitive method. The distortion component, which originate from harmonic currents, have to be combated using inductors or active harmonic conditioners. Rectifiers, inverters and frequency converters are only a few examples of components generating distortion reactive power. But normally only in industrial grids it may represent a real problem.

Operating behavior monitoring

Monitoring service intervals

Many operating resources must be maintained regularly. Their service intervals often depend also on the prevailing operating conditions. For monitoring these intervals three operating hour counters are provided, which by means of limit values, digital feedback signals or a suitable combination of the same may be used to determine the

- loads operating time under normal conditions
- loads operating time under overload conditions

Another operating hour counter is used to measure the time the APLUS itself has been switched on.

Protection of operating resources

To prevent malfunction or failure of equipment, such as generators, motors, heaters, cooling or computer systems, the permissible operating conditions are often tightly restricted. In order to protect such resources effectively you therefore have to examine if certain system quantities remain within the allowed range. For that quite often a combination of multiple limit values is necessary.

Universal logic analysis

The logic module shown below provides both the monitoring of service intervals and the effective protection of resources. This is achieved by logically combining the states of limit values, logic inputs and bus controlled information. Alarming and event or disturbance recordings are provided as possible actions.

Here is a selection of possible applications for the logic module:

- Functions of protective relays (e.g. over-current, phase failure or imbalance)
- Changeover of the present operating mode, such as e.g. local/remote (day/night) operation
- Controlling the recording of alarms, events and acknowledgment procedures
- Monitoring of external devices, such as circuit states or self monitoring signals

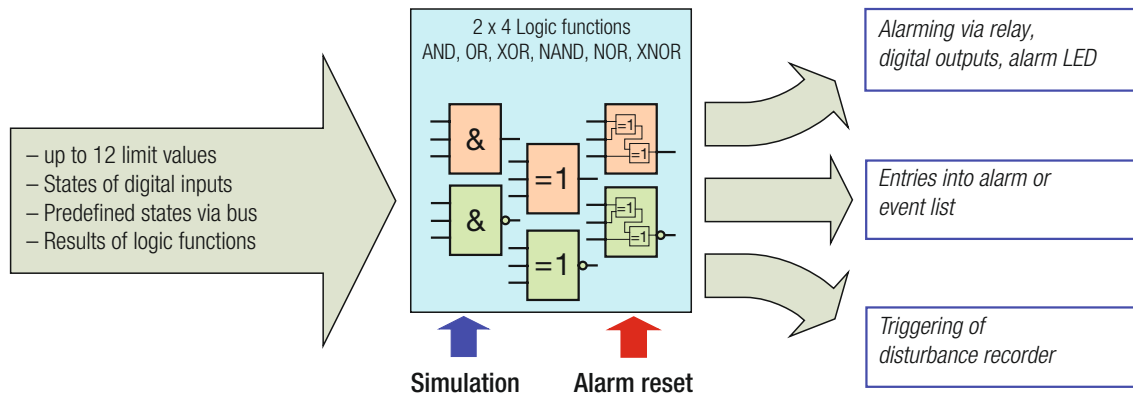

Long-term data storage with the data logger

The optional data logger offers the potential to record the behavior of a power system or load as well as the occurrence of definable events over a long period of time. Thus, for example, the following information may be collected:

- Consumption data for energy management
- Data about applied load for system expansion planning
- Measurement flows for incident analysis
- Recorded process flow

The data logger consists of data either recorded periodically or event-driven:

- Mean-values (power or user-definable quantities)
- Min/max values (RMS values within an interval)
- Meter readings, in calendric intervals
- Operator, alarm and event lists
- Disturbance records (RMS curves)

The storage medium used is an SD card, which allows virtually unlimited recording times and may be easily replaced in the field.

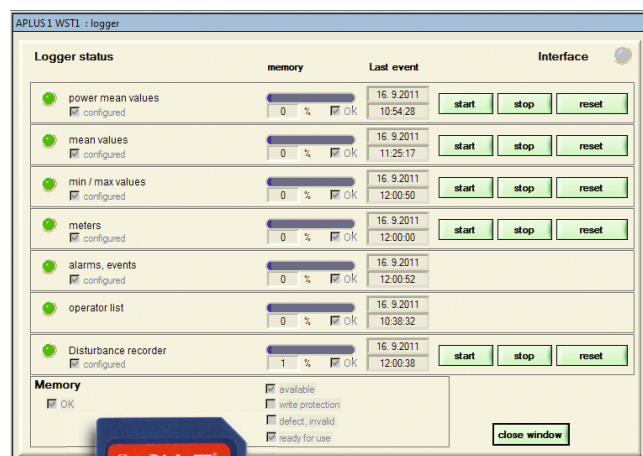

The display

- Clear and explicit display of measured data
- Free composition of measurement displays
- Alarm handling
- Device configuration
- Reset of minimum / maximum values
- Reset of meter contents
- Free definable plaintext display for alarming
- Preference display and roll mode

You may select optionally either a TFT or LED display for on-site data visualization. The TFT color display mainly focus on modern design, graphical analysis and language specific operation, whilst the LED display offers excellent readability, even from a distance and almost every angle. Both displays are operated via keys suited for industrial applications.

If needed access rights for both the user via display and via communication interface may be defined by activating the security system.



In addition to the existing display matrix the user may freely define and use its own assembly of measurements. The language of the user interface can be freely selected as well.

Along with the predefined display matrix the user may use a reduced or self-defined measurement assembly as well. In addition three different operating modes will be supported.

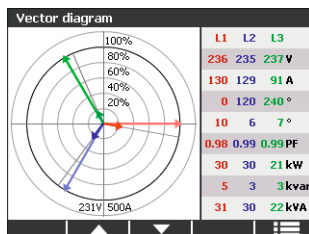

Vector diagram

A presentation of all voltage and current vectors and the present load situation.



Alarm display

Alarms may be signaled via the yellow LEDs and explained using plaintext. Alarms may be reset via display or remote controlled.

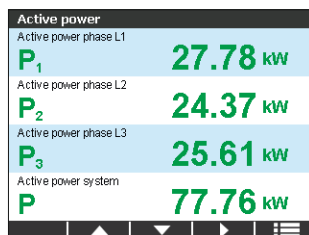

Measurement display

Measurements are displayed on four lines with plaintext explanation. Free measurement assemblies are possible.



Measurement display

Measurements are displayed on four lines. Free measurement assemblies are possible.

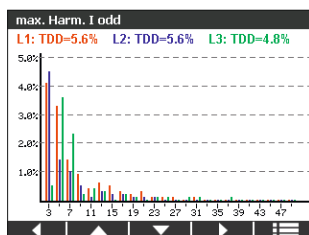

Harmonics

The individual harmonic contents of voltage and current are shown along with THD / TDD.



Meter reading

Up to 38 meter contents may be read using the meter reading mode.

Free composition of the required functions



Possible application of the I/Os

Relay outputs

- Alarming via lamp or horn
- Load shedding
- Remote controllable via bus interface

Digital inputs ¹⁾

- Alarm output of the logic module
- State reporting
- Pulse output to external counters (acc. EN62053-31)
- Remote controllable via bus interface

¹⁾ The digital I/Os of the I/O extensions can individually be configured for input or output.

Analog outputs

- Connection to PLC or another measurement system (e.g. CAM).
- All outputs are bipolar (± 20 mA) and galvanically isolated

Digital inputs ¹⁾

- Operating feedback of loads for operating hour counters
- Trigger and release signal for logic module
- Pulse input for any meter
- Meter tariff switching
- Synchronization (clock or mean-value intervals)

Order code **APLUS** -

1. Basic unit APLUS	
Without display, for top-hat rail mounting	0
With LED display, for panel mounting	1
With TFT-Display, for panel mounting	2
2. Input / frequency range	
Current transformer inputs, 45...50/60...65Hz	1
Rogowski current inputs, 45...50/60...65Hz	2
3. Power supply	
Nominal input voltage 24...230 V DC, 100...230 V AC	1
4. Communication interface	
RS485, protocol Modbus/RTU	1
Ethernet, protocol Modbus/TCP, NTP	2
RS485 (Modbus/RTU) + Profibus DP ²⁾	3
RS485 (Modbus/RTU) + RS485 (Modbus/RTU)	4
Ethernet (Modbus/TCP) + RS485 (Modbus/RTU)	5
5. I/O extension	
Without	0
2 relays, 4 analog outputs ± 20 mA, 2 digital I/Os	1
2 relays, 6 digital I/Os	2

6. Test certificate	
Without	0
Test certificate in German	D
Test certificate in English	E
7. Data logger	
Without data logger	0
With data logger ²⁾	1

Accessories	Order no.
Rogowski current sensor, single-phase, ACF3000_4/24	172 718
Doku-CD, Profibus-CD ³⁾	156 027
Connecting set 1 (plug-in terminals, mounting bracket) ³⁾	168 220
Connecting set 2 (plug-in terminals I/O extension) ³⁾	168 238
Interface converter USB <> RS485	163 189

²⁾ Data logger can not be combined with Profibus DP interface

³⁾ Scope of supply

Technical data

Inputs

Nominal current:	adjustable 1...5 A
Maximum:	7.5 A (sinusoidal)
Consumption:	$\leq I^2 \times 0.01 \Omega$ per phase
Overload capability:	10 A continuous 100 A, 10 x 1 s, interval 100 s

Current measurement via Rogowski coils

Measurement range: 0...3000A, auto-ranging
See operating instructions of Rogowski coil ACF3000_4/24 for further information

Nominal voltage:	57.7...400 V _{LN} , 100...693 V _{LL}
Maximum:	480 V _{LN} , 832 V _{LL} (sinusoidal)
Consumption:	$\leq U^2 / 3 M\Omega$ per phase
Impedance:	3 M Ω per phase
Overload capability:	480 V _{LN} , 832 V _{LL} continuous 600 V _{LN} , 1040 V _{LL} , 10 x 10 s, interval 10 s 800 V _{LN} , 1386 V _{LL} , 10 x 1 s, interval 10 s

Systems:	Single phase Split phase (2 phase system) 3-wire, balanced load 3-wire, unbalanced load 3-wire, unbalanced load, Aron connection 4-wire, balanced load, 4-wire, unbalanced load 4-wire, unbalanced load, Open-Y
Nominal frequency:	45... <u>50 / 60</u> ...65 Hz
Measurement TRMS:	up to 63rd harmonic

Measurement uncertainty



Version with Rogowski current inputs

The additional uncertainty of the Rogowski coils ACF 3000_4/24 is not included in the following specifications: See operating instructions of Rogowski coil ACF3000_4/24.

Reference conditions: Ambient 15...30°C, sinusoidal, (acc. IEC/EN 60688) measurement over 8 cycles, PF=1, frequency 50...60 Hz

Voltage, current:	$\pm (0.08\% MV + 0.02\% MR)$ ^{1) 2)}
Power:	$\pm (0.16\% MV + 0.04\% MR)$ ^{3) 2)}
Power factor:	$\pm 0.1^\circ$ ⁴⁾
Frequency:	± 0.01 Hz
Imbalance U,I:	$\pm 0.5\%$
Harmonics:	$\pm 0.5\%$
THD voltage:	$\pm 0.5\%$
TDD current:	$\pm 0.5\%$
Active energy:	Class 0.5S, EN 62 053-22
Reactive energy:	Class 2, EN 62 053-23

Power supply:	via plug-in terminals
Nominal voltage:	100...230 V AC $\pm 15\%$, 50...400 Hz 24...230 V DC $\pm 15\%$
Consumption:	≤ 7 VA

¹⁾ MV: measured value, MR: measurement range (maximum)

²⁾ Additional uncertainty for voltage measurement of 0.1% MV if neutral wire not connected (3-wire connections)

³⁾ MR: maximum voltage x maximum current

⁴⁾ Additional uncertainty of 0.1° if neutral wire not connected (3-wire connections)

I/O-Interface

Basic device:	1 relay output, changeover contact 1 digital output (fixed) 1 digital input (fixed)
I/O extension 1:	2 relay outputs, changeover contact 4 bipolar analog outputs 2 digital inputs/outputs
I/O extension 2:	2 relay outputs, changeover contact 6 digital inputs/outputs
Analog outputs:	via plug-in terminals, galvanically isolated
Linearization:	Linear, quadratic, kinked
Range:	± 20 mA (24 mA max.), bipolar
Uncertainty:	$\pm 0.2\%$ of 20 mA
Burden:	$\leq 500 \Omega$ (max. 10 V / 20 mA)
Burden influence:	$\leq 0.2\%$
Residual ripple:	$\leq 0.4\%$

Relays:	via plug-in terminals
Contacts:	changeover contact, bistabil
Load capacity:	250 V AC, 2 A, 500 VA 30 V DC, 2 A, 60 W

Digital inputs / outputs

Connection via plug-in terminals. For I/O extension individually configurable as input or output.

Inputs (acc. EN 61 131-2 DC 24 V Type 3):

Nominal voltage	12 / 24 V DC (30 V max.)
Logical ZERO	- 3 up to + 5 V
Logical ONE	8 up to 30 V

Outputs (partly acc. EN 61 131-2):

Nominal voltage	12 / 24 V DC (30 V max.)
Nominal current	50 mA (60 mA max.)
Load capability	400 Ω ... 1 M Ω

Interfaces

Modbus/RTU	via plug-in terminals
Physics:	RS-485, max. 1200 m (4000 ft)
Baud rate:	1,2 bis 115,2 kBaud
Number of participants:	≤ 32
Profibus DP	via 9-pin D-Sub socket
Physics:	RS-485, max. 100...1200 m
Baud rate:	automat. detection (9,6 kBit/s...12 MBit/s)
Number of participants:	≤ 32

Ethernet	via RJ45-connector
Physics:	Ethernet 100BaseTX
Mode:	10/100 MBit/s, full / half duplex, Auto negotiation
Protocols:	Modbus/TCP NTP (time synchronization)

Time reference: Internal clock (RTC)

Uncertainty:	± 2 minutes / month (15 up to 30°C), trimmable via PC software
--------------	---

Synchronization:	via synchronization pulse or NTP server
Running reserve:	> 10 years

Disposable measured quantities

Basic measured quantities

These measured quantities are determined using the configured measurement time (2...1024 cycles, in steps of 2 cycles). The display refreshment takes place with the refresh rate set.

Measured quantity	present	max	min	Measured quantity	present	max	min
Voltage per phase, system	•	•	•	Bimetal current per phase, system	•	•	
Mean value of voltages U_{mean}	•			Active power per phase, system	•	•	
Zero displacement voltage U_{NE}	•	•		Reactive power per phase, system	•	•	
Maximum $\Delta U <> U_{\text{mean}}^{1)}$	•	•	•	Apparent power per phase, system	•	•	
Phase angle of voltages	•			Frequency	•	•	•
Current per phase, system	•	•		Power factor per phase, system	•	•	
Mean value of phase currents	•			Power factor per quadrant			•
Neutral current I_{N}	•	•		Reactive power factor per phase, system	•		
Maximum $\Delta I <> I_{\text{mean}}^{2)}$	•	•		LF factor per phase, system	•		

Power quality analysis

These values are calculated about twice a second, depending on the system frequency.

Measured quantity	present	max	min	Measured quantity	present	max	min
Harmonic analysis				Imbalance currents / voltages			
THD voltage per phase	•	•		Symmetrical components [V]	•		
TDD current per phase	•	•		Symmetrical components [A]	•		
Harmonics voltage 2nd – 50th per phase	•	•		Imbalance voltage: negative/positive sequence	•	•	
Harmonics current 2nd – 50th per phase	•	•		Imbalance voltage: zero/positive sequence ⁴⁾	•	•	
Distortion reactive power per phase, system	•	•		Imbalance current: negative/positive sequence	•		
Fundamental reactive power per phase, system	•	•		Imbalance current: zero/positive sequence ⁴⁾	•	•	
$\cos\phi$ fundamental per phase, system	•		•				

Meters

Measured quantity	present	HT	LT	Measured quantity	present	HT	LT
Active energy incoming: per phase, system	•	•	•	Reactive energy outgoing system	•	•	•
Active energy outgoing system	•	•	•	Reactive energy inductive, capacitive system	•	•	•
Reactive energy incoming: per phase, system	•	•	•	I/O meters 1...7 ³⁾	•	•	•

Mean-values

As a standard the mean-values of the system power quantities are determined over the same programmable interval time t_1 . The interval time t_2 of the selectable mean-value quantities may be different but equal for all 12 quantities.

Measured quantity	present	trend	max	min	history	Measured quantity	present	trend	max	min	history
Active power incoming 1 s...60 min	•	•	•	•	5	Reactive power induct. 1 s...60 min	•	•	•	•	5
Active power outgoing 1 s...60 min	•	•	•	•	5	Reactive power capac. 1 s...60 min	•	•	•	•	5
Reactive power incoming 1 s...60 min	•	•	•	•	5	Apparent power 1 s...60 min	•	•	•	•	5
Reactive power outgoing 1 s...60 min	•	•	•	•	5	Mean-value quant. 1-12 1 s...60 min ⁴⁾	•	•	•	•	1

1) Maximum deviation from the mean-value of the 3 phase voltages

2) Maximum deviation from the mean-value of the 3 phase currents

3) Possible meters of the digital pulse inputs – any measurand and unit

4) Available via communication interface only, no indication on display

Ambient conditions, general information

Operating temperature: -10 ... 15 ... 30 ... + 55°C
 Storage temperature: -25 up to + 70 °C
 Temperature influence: 0.5 x basic uncertainty per 10 K
 Long term drift: 0.2 x basic uncertainty per year

Others: Usage group II (EN 60688)
 Relative humidity: < 95% no condensation
 Altitude: ≤ 2000 m max.
 Device to be used indoor only!

Mechanical attributes

Orientation: Any
 Housing material: Polycarbonat (Makrolon)
 Weight: 500 g
 Flammability class: V-0 acc. UL94, self-extinguishing, non-dripping, free of halogen

APLUS without display for top-hat rail mounting

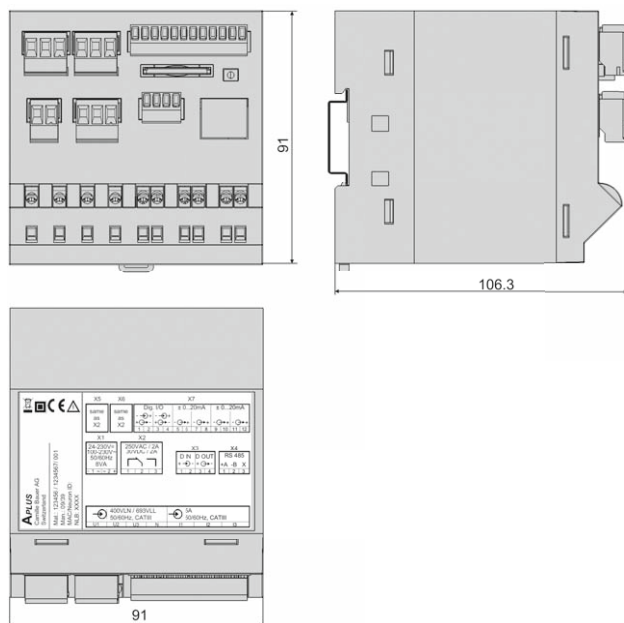

APLUS with display for panel mounting

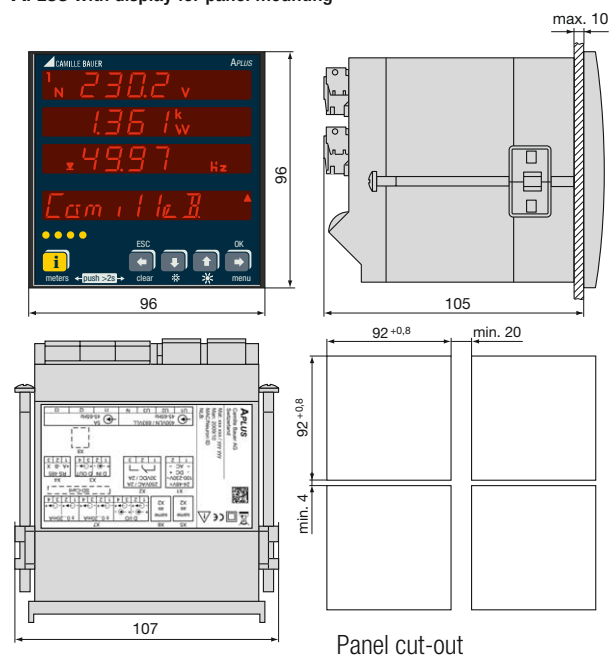

Safety

The current inputs are galvanically isolated from each other.
 Protection class: II (protective insulation, voltage inputs via protective impedance)
 Pollution degree: 2

Protection rating: IP64 (front), IP40 (housing), IP20 (terminals)
 Measurement category: CAT III, CATII (relays)

Applied standards, regulations and directives

IEC/EN 61 010-1	Safety regulations for electric measuring, control and laboratory equipment	IEC/EN 61 000-6-2/ 61 000-6-4:	Electromagnetical compatibility (EMC) Generic standards for industrial environment
IEC/EN 60 688	Electrical measuring transducers for converting AC electrical variables into analog or digital signals	IEC/EN 61 131-2	Programmable controllers – equipment, requirements and tests (digital inputs/outputs 12/24V DC)
DIN 40 110	AC quantities	IEC/EN 61 326	Electrical equipment for measurement, control and laboratory use – EMC requirements
IEC/EN 60 068-2-1/ -2/-3/-6/-27:	Ambient tests -1 Cold, -2 Dry heat, -3 Damp heat, -6 Vibration, -27 Shock	IEC/EN 62 053-31	Pulse output devices for electromechanical and electronic meters (SO output)
IEC/EN 60 529	Protection type by case	UL94	Test for flammability of plastic materials for parts in devices and appliances
2002/95/EG (RoHS)	EC directive on the restriction of the use of certain hazardous substances		

Energy consumption data: Reading, recording and compiling

It is often necessary to read out measured values in a simple manner via a communication interface, to store the same and to present it in tabular or graphic form. Camille Bauer Metrawatt AG meets this need with the SmartCollect software package. Using this software package, you will be able to perform this task quickly, simply and, above all, safely. SmartCollect may be used for data readout and storage at specified time intervals. The most varied kinds of measuring instruments may be attached. Read-out data is stored in a Microsoft SQL server database. Both real time values and historic signal courses may be represented.

The following protocols and devices are supported:

- Modbus TCP
- Modbus RTU (RS485)
- OPC DA 2.0
- Camille Bauer videographic recorders via HTTP
- Direct communication with the multifunctional «SmartControl» data collector of Gossen Metrawatt

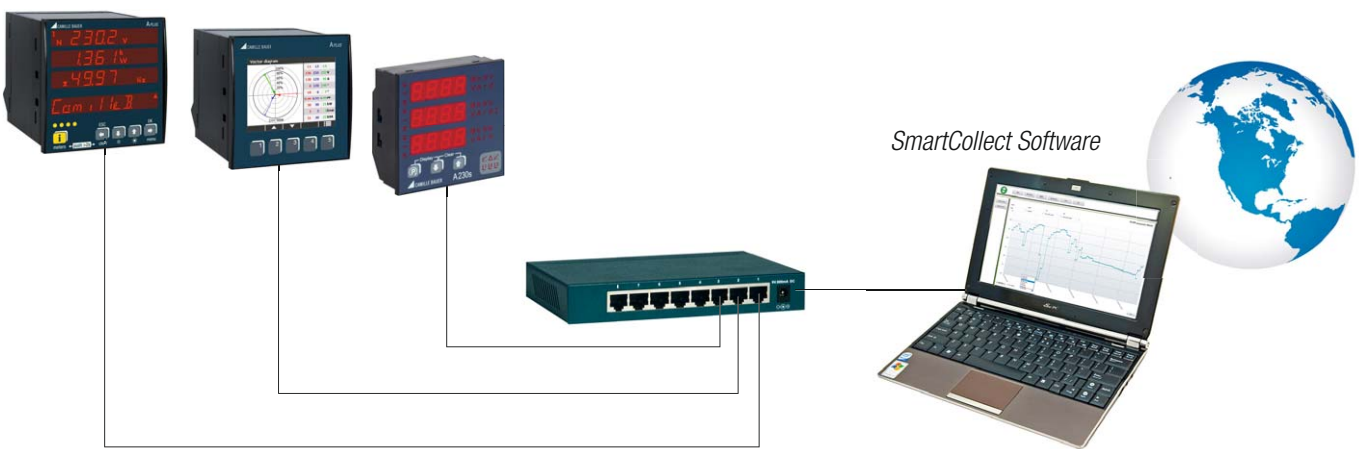

Application: Read-out of data with Modbus TCP. The measurement data of all Camille Bauer Power Meters and / or top-hat rail transducers can be recorded and processed.